

In designing Auckland, Jean Marie Massaud undertakes a restatement, in a contemporary key, of the classic lounge chair, which serves to reconfirm the original looks and comfort of this timeless classic. The seat of this swivel chair, available in black or white with optional foot-rest, is characterised by the seat's shell-shaped structure, left deliberately exposed to evoke the armour worn by Kendo fighters. The shell protects the upholstered parts of the chair and is linked to the four-spoked base by a cantilevered metal support. This unusual arrangement confers a very faint, yet pleasurable, oscillating movement. The chair is complemented by a head-rest adjustable to eight height-options.

## Gallery

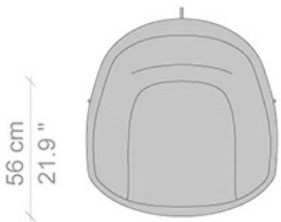

## Dimensions

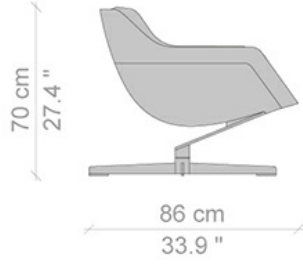
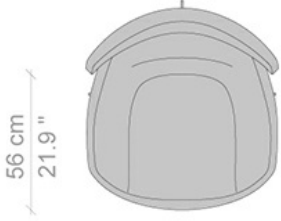
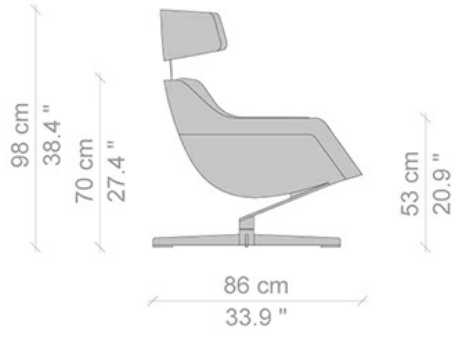
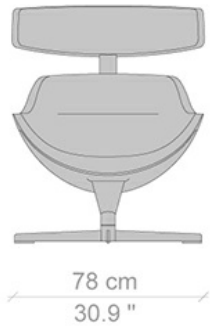

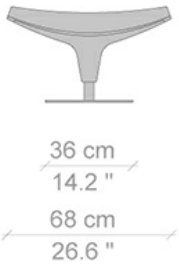

## Designer



**Jean-Marie Massaud**

Born in Toulouse in 1966, Jean-Marie Massaud graduated in 1990 from Les Ateliers, Ecole Nationale Supérieure de Création Industrielle, Paris. He began to work both in Asia and in France, finally opening his own office in Paris in 1994. Since then, he has dedicated himself to industrial and furniture design, building important relationships with brands such as Authentics, Baccarat and Magis. His collaboration with Marc Berthier and his work in the field of town planning led him towards design and architecture. He is concerned with design in various contexts, industrial products and furniture. His contextual approach centres on research into the essential, within which the individual remains the centre of attention. It is a work upheld by research into the senses, magic, and vital emotion which brings him to work with very different brands: Cassina, Poltrona Frau, Cappellini, Cacharel, Lancôme, Tronconi and Yamaha offshore. His works have been awarded several prizes and many of his designs are nowadays on show in the design collections of the major museums worldwide: from Amsterdam, Chicago, London, Paris and Zurich: from the permanent collection of the Musée National d'Art Moderne de Paris to the permanent collections of the Museum für Gestaltung, Zürich, of The Chicago Athenaeum- Museum of Architecture and Design, of The Stedelijk Museum, Amsterdam and of The Musée des arts Décoratifs, Paris.