



NOTES | INDOOR - OUTDOOR + LAZY SUSAN

design Massimo Mariani

Notes

Table available for indoor and outdoor use, with granite, smoked glass, transparent glass, or porcelain stoneware top (for indoor and outdoor use), with wood and marble top (for indoor use only) and tubular steel frame Ø30 mm with steel connection crossbars section 80x15 mm with galvanized coating and with epoxy polyester powder coating in Gunmetal grey color. Floor support provided by black plastic tips. Top 20 mm thick in finishes Black Absolute Zimbabwe granite, Bianco Carrara, Nero Marquina, Sahara Noir and Rosso Levanto marbles, or top 12 mm thick in porcelain stoneware in Natural Kaolin or Balance Smoke color shades; all the marble, stone, and ceramic tops are supported by a black-painted Doluflex under top, coupled with anti-slip material, and plates featuring conical recess for centering and fixing to the base. Marble version with satin finish and transparent matte protective coating, or glossy/matte polyester finish. Wooden top in MDF "sandwich" and aluminum sheet pressed and bonded together with beveled edge, veneered in natural and charcoal-dyed chestnut, or Stone Oak® with water-based coating, or in multilayer wood veneer Striped Grey with acrylic coating; bevel and bottom always lacquered in matte black coating. Top 12 mm thick in tempered glass available in transparent or smoked glass, with UV rays bonded plates featuring conical recess for centering and fixing to the base. All versions of the top are secured to the base using tie rods.

Lazy Susan

Rotating centerpiece available in marble, porcelain stoneware, or wood in sizes Ø70, Ø90 e Ø110 h.4 cm, with black laminated HPL support base 10 mm thick and rotating mechanism "sandwich-inserted" between the top and the support frame.

Floor support provided by black plastic rubber feet.

Marble top version: top 20 mm thick with beveled edge, available in Nero Marquina, Bianco Carrara, Rosso Levanto or Sahara Noir marble with glossy polyester finish.

Porcelain stoneware top version: top 12 mm thick with beveled edge, available in Natural Kaolin or Balance Smoke color shades.

Wooden top version: top 20 mm thick in MDF with beveled edge, veneered in natural and charcoal-dyed chestnut, or Stone Oak® with water-based coating; bevel and bottom always lacquered in matte black coating.

Structure



Gunmetal Grey
Lacquering
(In-Outdoor)

Piano

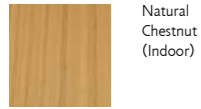

Natural
Chestnut
(Indoor)



Charcoal-dyed
Chestnut
(Indoor)



Stone Oak®
(Indoor)



Striped Grey
(Indoor)

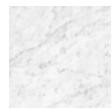

Bianco Carrara
Marble
(Indoor)

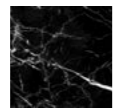

Nero Marquina
Marble
(Indoor)

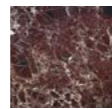

Rosso Levanto
Marble
(Indoor)

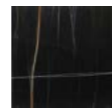

Sahara Noir
Marble
(Indoor)

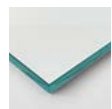

Transparent
Glass
(In-Outdoor)

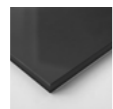

Smoked
Glass
(In-Outdoor)



Black Absolute
Zimbabwe
Granite
(In-Outdoor)



Balance Smoke
Porcelain
Stoneware
(In-Outdoor)



Natural Kaolin
Porcelain
Stoneware
(In-Outdoor)

Lazy Susan (solo Indoor)



Natural
Chestnut



Charcoal-dyed
Chestnut



Stone Oak®

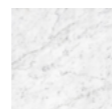

Bianco Carrara
Marble

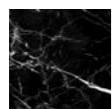

Nero Marquina
Marble

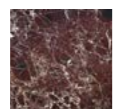

Rosso Levanto
Marble

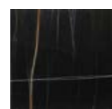

Sahara Noir
Marble



Balance Smoke
Porcelain
Stoneware



Natural Kaolin
Porcelain
Stoneware

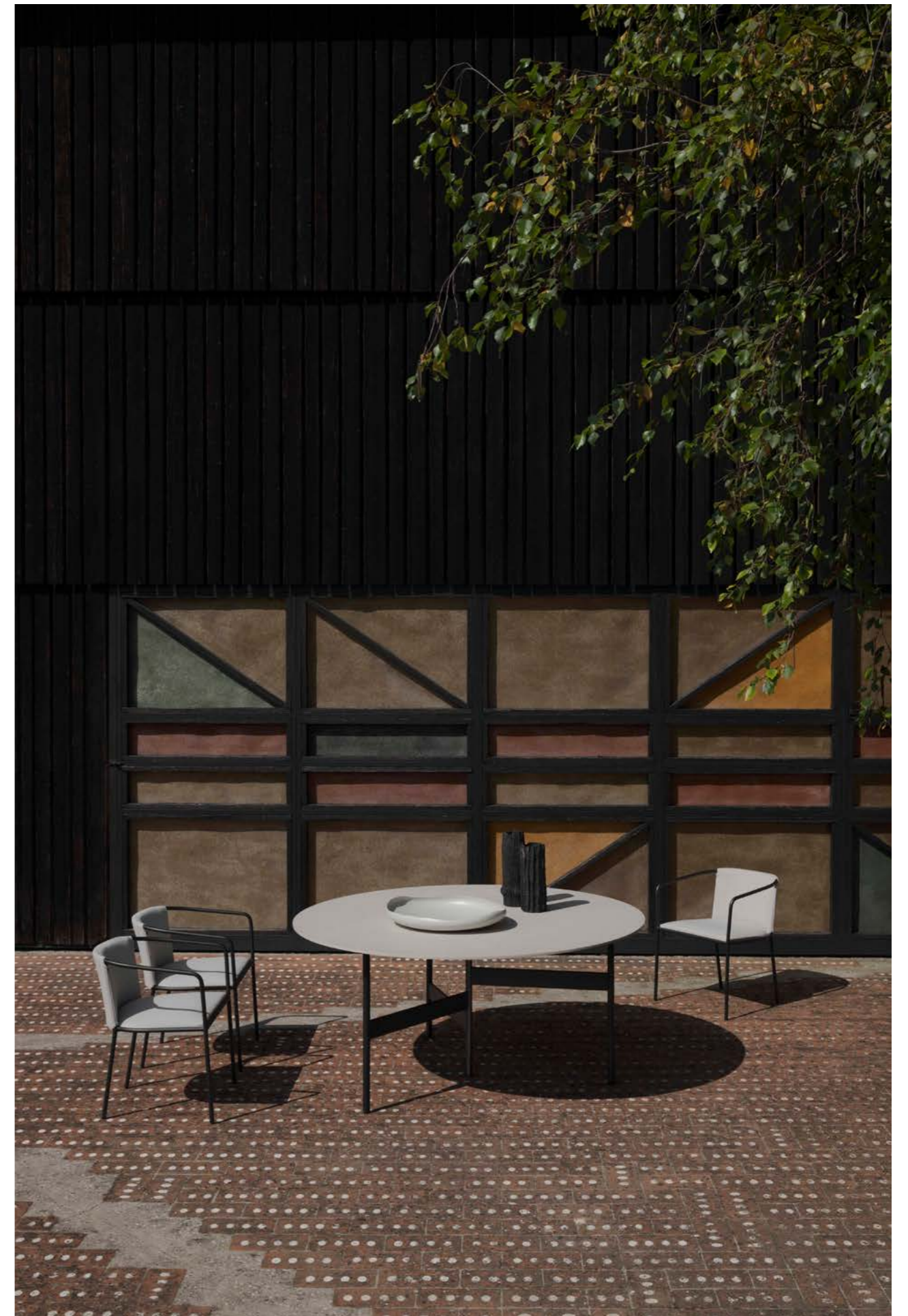

Technical Drawings
Table

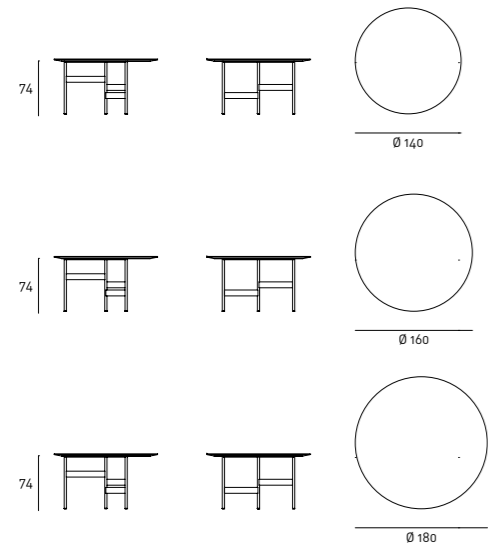

Lazy Susan in marble

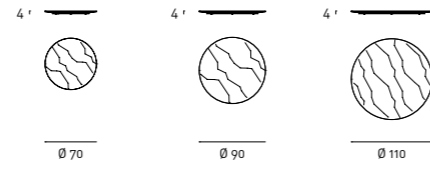

Lazy Susan in wood

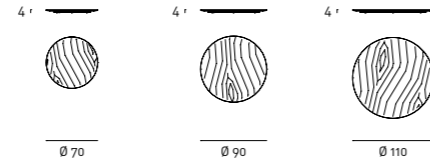
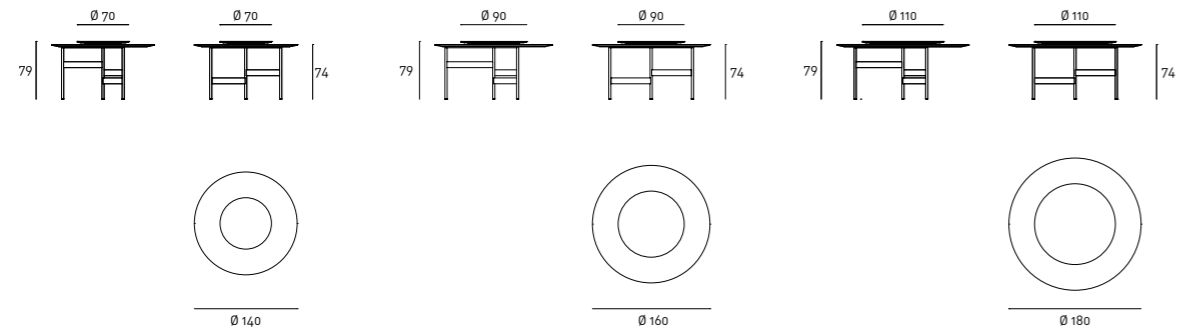

Table + Lazy Susan



Notes

GRANITE: of uniform colour, granite is a hard stone of volcanic origin and is an "intrusive rocks", which emerge from solidified magma inside the earth's crust; for its particular nature, granite is a very resistant material to abrasion and compression and easy to be maintained.

Wood is a living material; therefore, it can have slight color and dimension changes. The presence of any non-homogeneous color shades is not to be considered a defect but a quality. Please note that the direct sunlight exposure may alter the wood color; therefore, we recommend the periodic position shift of the objects placed on the furniture for the first months to avoid differences in shades between exposed and covered portions.

STRIPED GREY: it is a decorative multilaminar wood veneer, always finished with a transparent acrylic painting, which features exclusive patterns reproducing the natural characteristics of wood. We would like to remind you that, being a natural and living wooden material, it may present non-homogeneous colour shades, which are peculiarities of the material itself.

STONE OAK®: this wood owes its particular coloring to an entirely natural process. Because of this, some slabs may look more brown than others. Our commitment is to provide you a high-quality product; any differences in color should not be considered as defects.

On request, an additional protective (acrylic solvent) painting is available for the Stone Oak® finishing only. It should be noted that this additional coating slightly changes the natural color and texture of the surface. Although this supplementary painting increases the surface resistance, it is still a natural material; therefore, small superficial stains, due to oil or other substances, must be promptly removed, before being absorbed in depth by the wood. Thus, we recommend regular care and maintenance.

For the marble top version please specify the required finish in the order.

For marble finishing with opaque matt polyester finish, the "Marble" Maintenance Kit is included with the product.

For the **OUTDOOR** version, we recommend placing the product on terraces or verandas to guarantee its durability over the years. It is recommended to use a "Protective Cover" to improve the longevity of the product. For further information about the dedicated maintenance, please refer to the technical sheet available in the "Materials" section on our website.

Although the Lazy Susan can endure high temperatures, it is advisable to avoid placing (directly on the top) tools just removed from heat sources. The direct contact with overheated objects could cause indelible stains or crevices, created by the thermal shock. Therefore, it is advisable to always use a trivet to place the dishes on the surface.

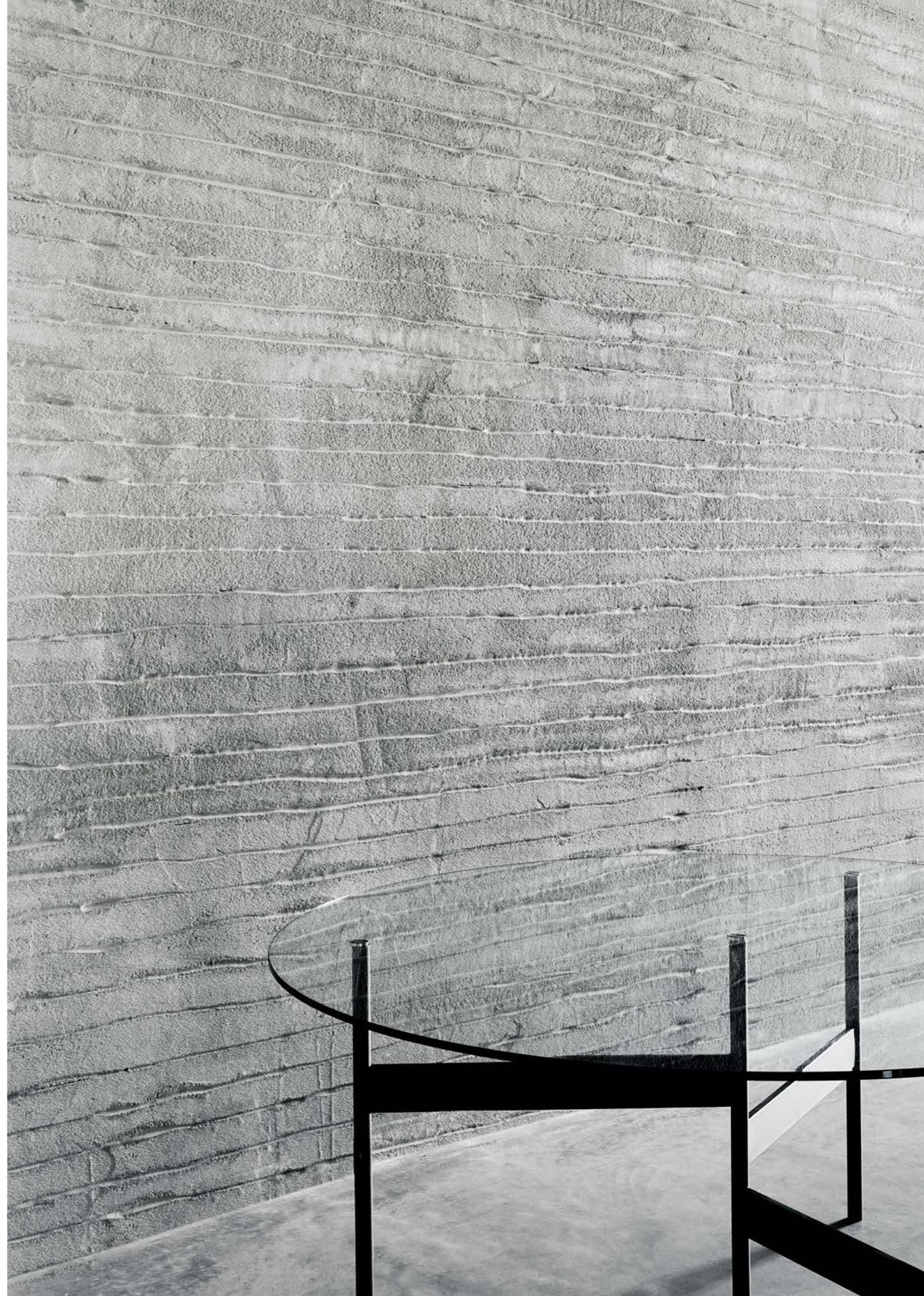

Notes table with top in granite



Notes table with top veneered in charcoal-dyed chestnut and Lazy Susan in Sahara Noir marble

