

Soft Work

Edward Barber & Jay Osgerby, 2018 / 2024

vitra.



Soft Work

Edward Barber & Jay Osgerby, 2018 / 2024

The Soft Work office seating system embodies Vitra's expertise from the home, office and public sectors. Instead of creating a working environment centred around desks with peripheral sofas, Soft Work has developed into a system in which table workstations are focused around a seating landscape. The designers Edward Barber and Jay Osgerby see this as a long-term development: 'The workstation is going the same way as the dining room – it's disappearing as an archetype. The desk has had its day. With mobile technology you need a place to sit occasionally, or a comfortable place to hang out. That's our belief.'

Soft Work offers a versatile platform for both individuals and teams. Besides ergonomic seating options, users also find practical table surfaces, power outlets and charging stations. Mobile tables and chairs can be pulled up as needed and put away again, and the addition of panels creates spaces for quiet, concentrated work. Thanks to its modular concept, Soft Work can be easily assembled into diverse arrangements, enabling architects to structure the internal spaces of a building, create specific focal points, or define flexible public areas.



1-9	Soft Work	16-17	Single bench, linear & curved	26-27	Electrification
10-11	Modular system	18-19	Double bench, linear & curved	28-29	Soft Work on castors
12-13	Frame and legs	20-21	Table modules	30-37	Configurations
14	Single bench	22-23	Accessories	38-39	Upholstery
15	Double bench	24-25	Screens	40-48	Colours and materials



lounge



welcome area





meeting space



focus space



workspace



cafeteria



workshop space

Modular system

vitra.

vitra.

Modular system for versatile configurations

The supporting unit consists of a frame construction on a leg base, which can be endlessly extended as required with the aid of frame connectors. The frame accommodates all modules and accessories. Linear frames form the base structure; concave and convex curves in 30° segments round off the system. Curved and linear frames can be combined.

Various side elements and side screens are available as lateral end components.

Functional accessories for ergonomic work postures

Accessories and partition screens can be inserted between two upholstered seat modules.

All covers can be removed with low to moderate effort should the product require maintenance.

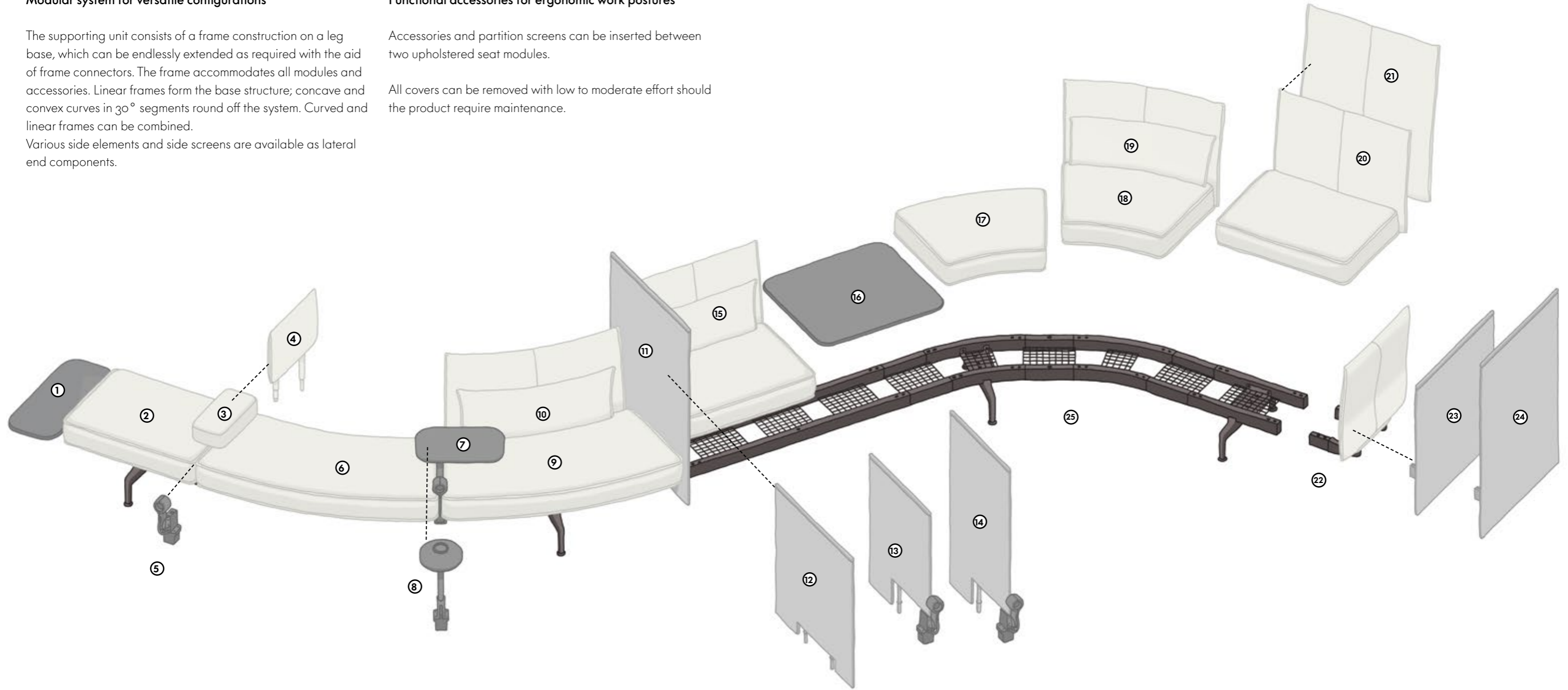

- 1 Side table, single
- 2 Platform module 80
- 3 Armrest
- 4 Partition panel
- 5 Flip-up socket

- 6 Platform module 30° convex
- 7 Swivel tablet
- 8 Fixed tray
- 9 Seat/back module 30° convex
- 10 Lumbar cushion 30° convex

- 11 Partition screen wide, high
- 12 Partition screen wide, low
- 13 Partition screen narrow, low
- 14 Partition screen narrow, high
- 15 Lumbar cushion 80

- 16 Table module 80
- 17 Platform module 30° concave
- 18 Seat/back module 30° concave
- 19 Lumbar cushion 30° concave
- 20 Seat/back module 80 lowback

- 21 Seat/back module 80 highback
- 22 Side panel, curved
- 23 Side screen, low
- 24 Side screen, high
- 25 Profile frame with leg bases and optional cable baskets

Frame and legs – two units

vitra.

Two-unit configurations can be equipped with seat modules (highback or lowback) and table elements.

For stability reasons, configurations with two units cannot be fitted with side tables – only side panels and side screens.



The frame is powder-coated in black.

The legs are available in two versions: a black powder-coated finish or in polished aluminium.



03
polished
aluminium

30
basic dark
powder-coated
(textured)

Frame and legs – three or more units

vitra.

Configurations with three or more units can be equipped with seat modules (highback or lowback) and table elements.

They can also be fitted with extra elements, such as the add-on table, side table or side screen.



These configurations may also be further expanded. A central leg is required for 5 units or more.

pCon.planner can be used to easily plan required configurations and will automatically calculate all the part requirements.

Single bench

vitra.

With single rows (single benches), seat/back and platform modules can be mixed.



Single bench: with platform module 80 and seat/back modules 80 lowback



Single bench: with seat/back modules 80 lowback



Single bench: with platform modules 80

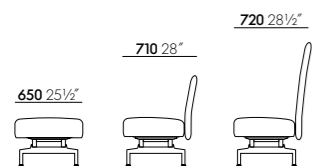

Double bench

vitra.

With double rows (double benches), it is not possible to mix seat/back and platform modules, as they have different depths.



Double bench: with seat/back modules 80 lowback



Double platform: with platform modules 80

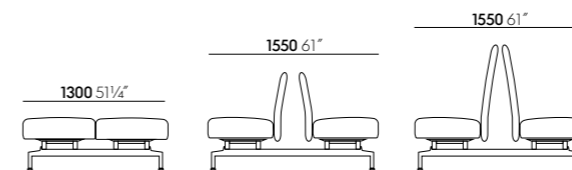

Single bench, linear

vitra.

The seat modules are designed as 80 cm-wide elements

Lumbar cushions are available to match the seat/back modules. They sit loosely and are optional. The use of cushions is recommended for optimum comfort.

There are seat/back modules and backless platform modules. The linear configuration of seat/back modules is also available in a highback version.

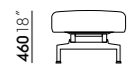
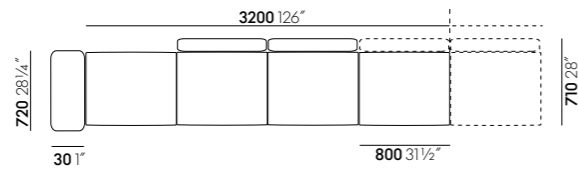

Platform module 80

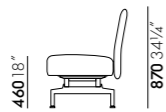

Seat/back module 80 lowback

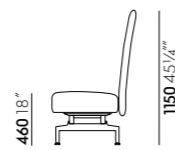

Seat/back module 80 highback

Single bench, curved

vitra.

The seat module comes with a 30° concave or convex curve.

Lumbar cushions 30° concave and convex are available to match the seat/back modules 30° concave and convex. They sit loosely and are optional for enhanced seating comfort.

There are seat/back modules and backless platform modules. The seat/back module 30° is only available in a lowback version.

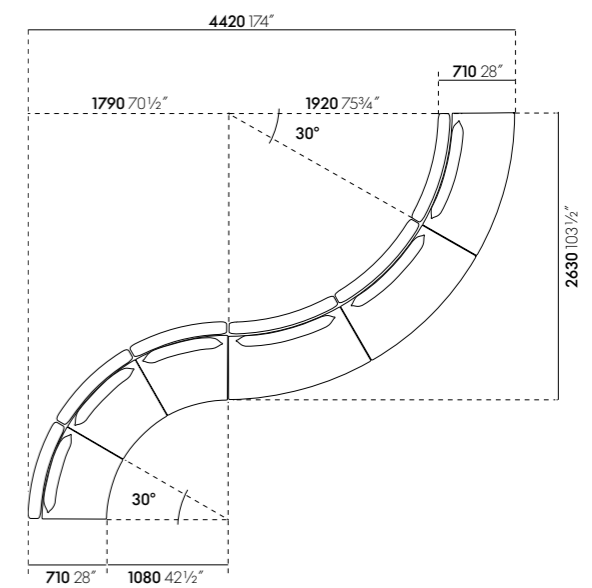
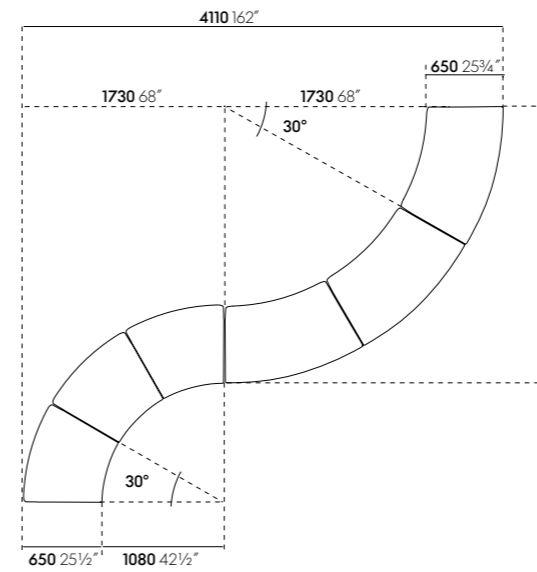

Platform module 30° concave
Platform module 30° convex



Seat/back module 30° concave
Seat/back module 30° convex

Double bench, linear

vitra.

Modular dimensions and space requirements

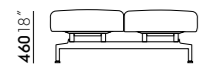
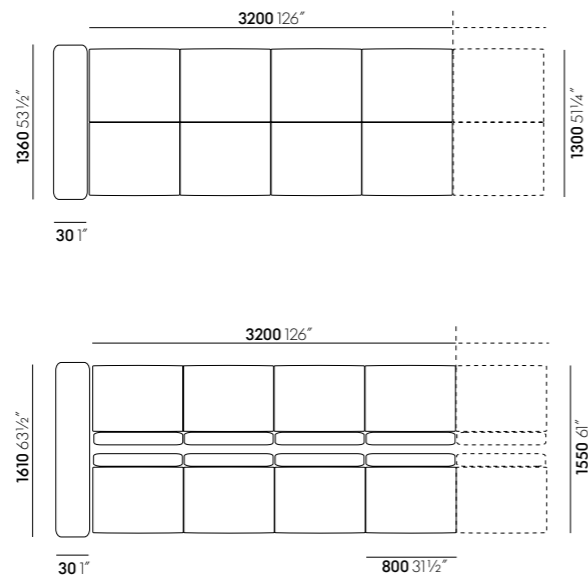

Platform module 80

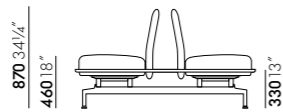

Seat/back module 80 lowback

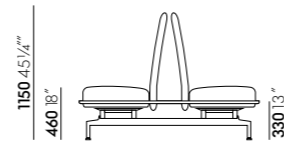

Seat/back module 80 highback

Double bench, curved

vitra.

Modular dimensions and space requirements

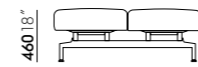
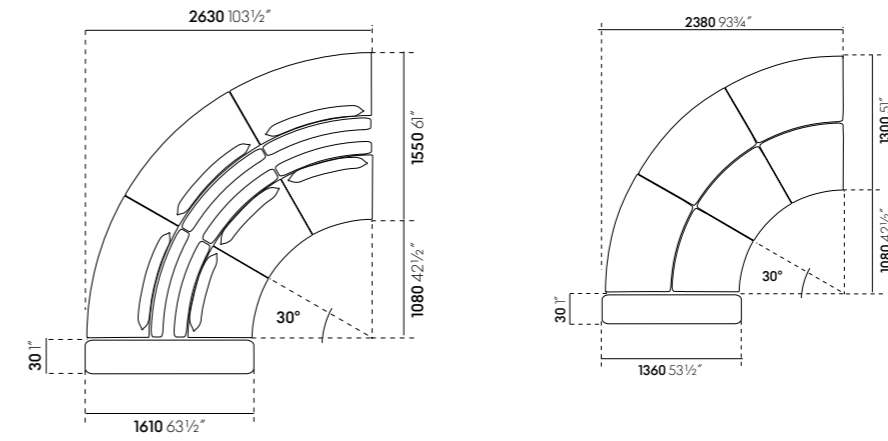

Platform module 30° concave
Platform module 30° convex

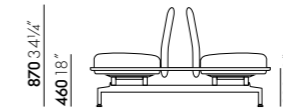

Seat/back module 30° concave
Seat/back module 30° convex

Table modules

Table modules are orthogonal and designed in 80 cm-wide elements, and can be used in place of linear seat modules. Table modules are available for singles benches (depth 720 mm) and in end-to-end depth for double benches (depth 1610 mm) or double platforms (depth 1360 mm).

vitra.

vitra.



Table module 80 single
W 790 x D 720 mm



Table module 80 double
W 790 x D 1610 mm



Table module 80 double for platform
W 790 x D 1360 mm



Corner table 90°
W 720 x D 720 mm
The 90° corner table can combine single linear benches at a 90° angle.
It cannot be used with curved elements.



Side table, single
W 300 x D 720 mm



Side table double
W 300 x D 1610 mm



Side table double for platform
W 300 x D 1360 mm

Table surfaces



MDF powder-coated in soft light 52
25 mm thick



MDF powder-coated in deep black 12
25 mm thick



Particle board in melamine soft light
ABS edge in black 52, 25 mm thick



MDF with light oak veneer 17
25 mm thick

Side panel

vitra.



Side panel H 630 x W 120 x D 660 mm

Softly upholstered side end element for single bench. Two side panels are required with double benches. Not intended for use adjacent to a platform module. For aesthetic reasons, it is not recommended for use with highback modules or screens.

Accessories

Accessories can be fitted to the frame between two upholstered seat modules – except where legs are located. A holder is required for mounting most accessories on the frame.



Fixed tray: W 220 x D 285 mm

Tubular steel in basic dark with table top, powder-coated MDF in soft light or deep black. Integration of Punto USB Wireless Charging* is optional.



Swivel tablet: W 310 x D 470 mm

Double swivel arm in aluminium, with polished finish or powder-coated in basic dark; pivotable table top, powder-coated MDF in soft light or deep black.



Armrest: H 120 x W 190 x D 390 mm

Softly upholstered; can be mounted directly on frame. If a flip-up socket is required, a holder will be necessary.



Partition panel: H 310 x W 70 x D 480 mm

Softly upholstered; can be mounted directly on frame. If a flip-up socket is required, a holder will be necessary.



Flip-up socket

Pivotable plastic housing in basic dark, for 1x power or 2x USB type A. Swivel-mounted below seat, socket attaches to frame via holder and can be combined with all accessories.

Mounting accessories with and without holder

vitra.

Mounting without holder

1. Partition panel
2. Armrest

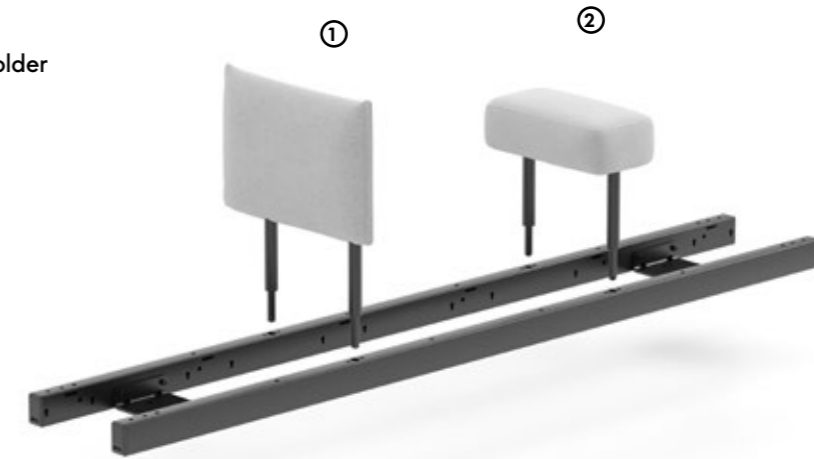

Mounting with holder

1. Flip-up socket
2. Fixed tray, with and without flip-up socket
3. Swivel tablet, with and without flip-up socket
4. Partition panel, with flip-up socket
5. Armrest, with flip-up socket

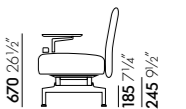
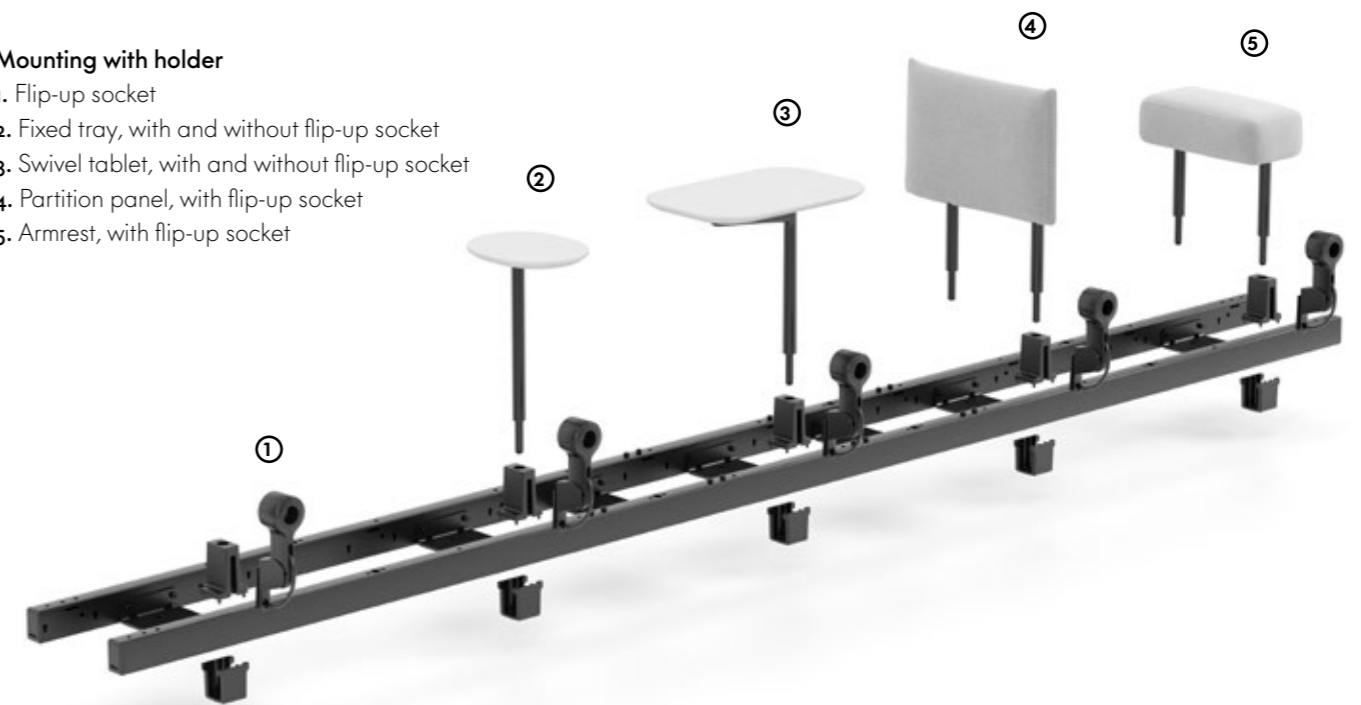

***Punto USB Wireless Charging:** Qi-certified wireless charger, output of 5 volts at 1.5 amps, for charging all Qi-compatible devices. Trim ring (diameter 84 mm) in polished aluminium mounted flush with table top; with soft rubber ring to support the mobile phone on the charger. Incl. power cable and mains unit.

Screens

vitra.

Screens are available as lateral side elements or to separate upholstered seat/back modules. They come in two different heights for varying degrees of privacy. The slim steel frame construction with a thin cut-foam filling is

available in all Plano colours. An upper cover strip forms a neat edge and is available in aluminium, gloss-anodised or powder-coated in basic dark. Screens are not generally suited for mounting on or between platform or table modules.



Side screen: for mounting on open frame ends using side screen holder.

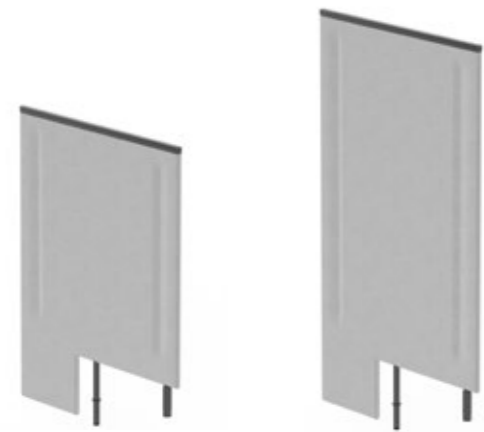

Partition screen narrow: for mounting between upholstered seat modules. A holder is required for mounting, and can also be equipped with a flip-up socket.

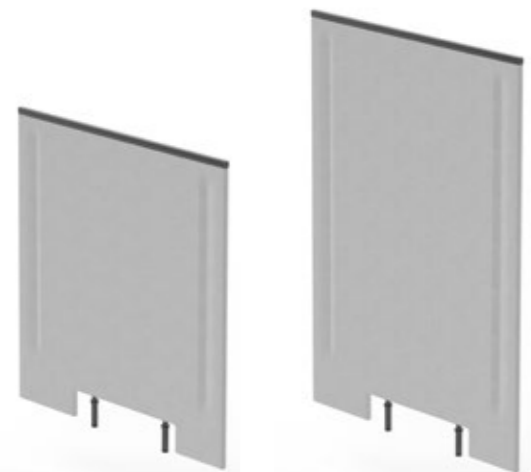

Partition screen wide: for mounting between upholstered seat modules directly on frame.

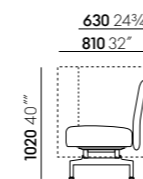

Side screen, partition screen narrow and partition screen wide, low

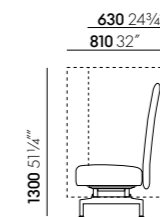

Side screen, partition screen narrow and partition screen wide, high

vitra.

Cable baskets suspended beneath the Soft Work frame, without the need for tools, offer easy access to power and data. The feed cable is routed through a cable channel and connected to a distributor. The entire configuration can then be supplied with power and data connections as required, with sockets fitted without the need for tools.

Cables and accessories

A suitable electrification package is offered for the flip-up socket and/or fixed tray with wireless charging. Feed cables, connecting cables and distributors must be individually planned and ordered in accordance with the configuration. Please observe the electrical regulations valid in your country.

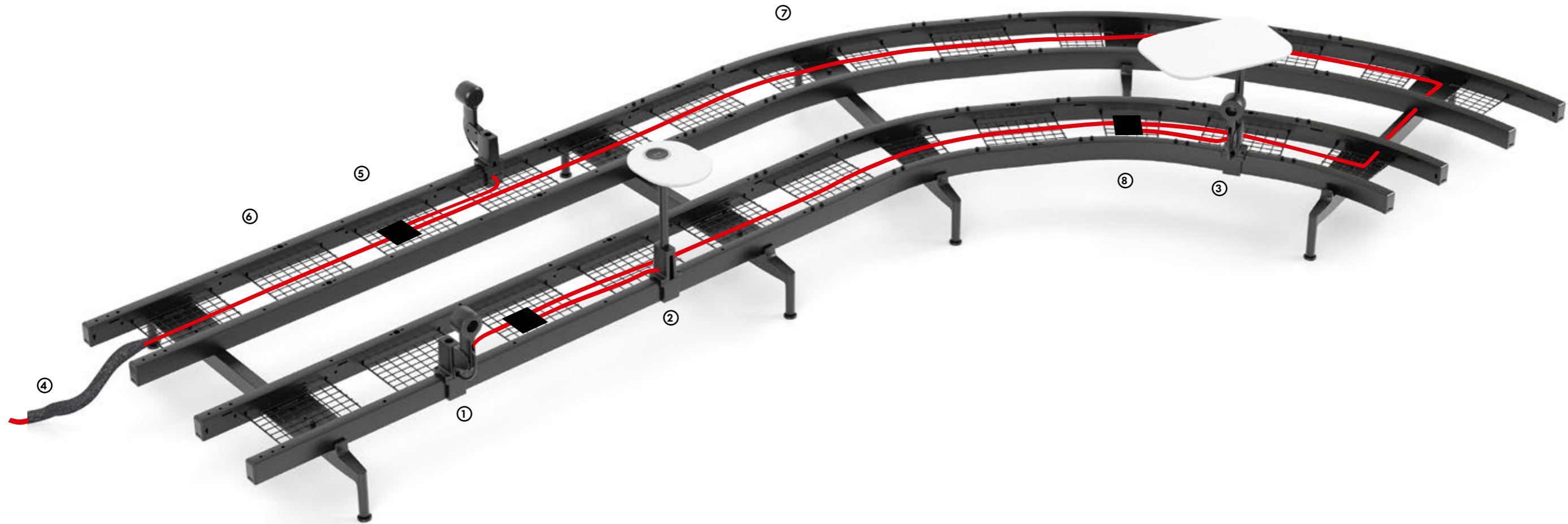

Electrification

1. Flip-up socket
2. Fixed tray, with and without flip-up socket
3. Swivel tablet, with and without flip-up socket
4. Cable channel
5. Distributor

6. Cable basket, linear
7. Cable basket, convex
8. Cable basket, concave

The following articles are available for cable management:

Cable basket: made of welded wire, Ø 4 mm, powder-coated in basic dark

- Cable basket 80 for all linear frames. Cable baskets can be attached as follows: frame for 1 module: 1 piece; frame for 2 modules: 3 pieces; frame for 3 modules: 5 pieces; frame for 4 modules: 7 pieces
- Cable basket 30° concave: 1 piece per seat/back module 30° concave or platform module 30° concave
- Cable basket 30° convex: set of 2 pieces per seat/back module 30° convex

- Cable basket 30° convex for platform: set of 2 pieces per platform module 30° convex

Cable channel

Distributor

Feed cable

Connection cable

Electrification set for flip-up socket

Electrification set for wireless charger

Soft Work is available on castors for even greater flexibility, transforming the sofas into central adaptable elements within agile office environments. The seating arrangements can be spontaneously reconfigured to suit the workplace dynamics or the project at hand – and should additional space be needed, the sofas can be easily pushed to one side.

Configurations on castors cannot be electrified.



Possible configurations on castors

	2 modules	3 modules	4 modules
Single bench, linear	•	•	•
Double bench, linear	•	–	–
Single bench, curved	–	•	–
Double bench, curved	–	–	–

Accessories, table modules and add-on elements

Intermediate tables can be fitted in place of seats and add-on tables, while side screens and side panels may be added to configurations of three elements or more. It is also possible to insert accessories, which are mounted on the frame between two upholstered seat modules – except where legs are located. Holders are required for most accessories.



Frame, legs and castors

The frame is powder-coated in black, and the castors are also black. The legs are available in either a black powder-coated finish or in polished aluminium.



03 polished aluminium



30 basic dark powder-coated (textured)

Configurations

vitra.

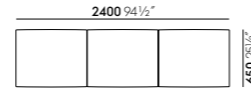

Soft Work platform 3-seater on castors. Cover fabric: Credo, 01 cream.

vitra.

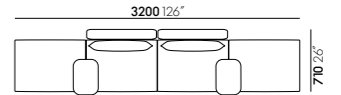

Soft Work sofa 4-seater, with platform modules and swivel tablets incl. flip-up socket. Cover fabric: Credo, 06 anthracite/elephant.

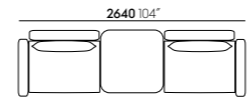

Soft Work sofa 2-seater, with table module and side panels. Cover: Leather, 97 cognac.

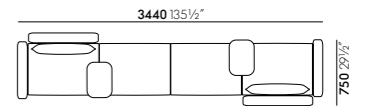

Soft Work sofa 4-seater, with platform modules, side panels and swivel tablets incl. flip-up socket. Cover: Leather, 22 red stone.

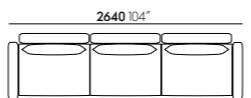

Soft Work sofa 3-seater on castors, with side panels. Cover fabric: Cosy 2, 15 rusty orange.

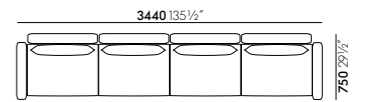

Soft Work sofa 4-seater, with side panels. Cover fabric: Laser, 30 light grey/poppy red.

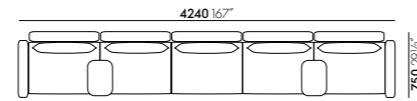

Soft Work sofa 5-seater, with side panels and swivel tablets incl. flip-up socket. Cover fabric: Cosy 2, 17 reed green.

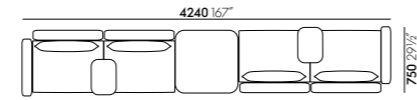

Soft Work sofa 4-seater, with table module, side panels and swivel tablets incl. flip-up socket. Cover fabric: Volo, 11 night blue.

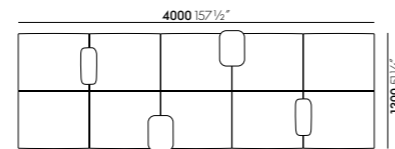

Soft Work platform 5-seater double, with armrests and swivel tablets incl. flip-up socket. Cover: Leather, 64 cement.

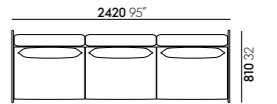

Soft Work sofa 3-seater on castors, highback with side screens. Cover fabric: Credo, 21 royal blue/elephant.

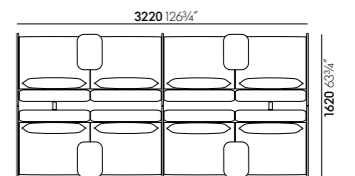

Soft Work sofa 4-seater double, highback with screens and swivel tablets incl. flip-up socket. Cover fabric: Credo, 26 teal blue/black.

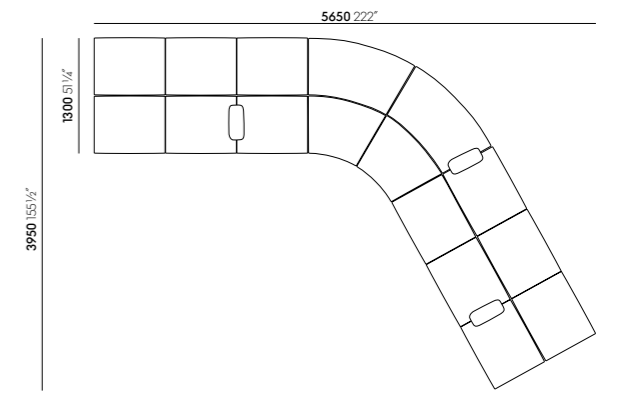
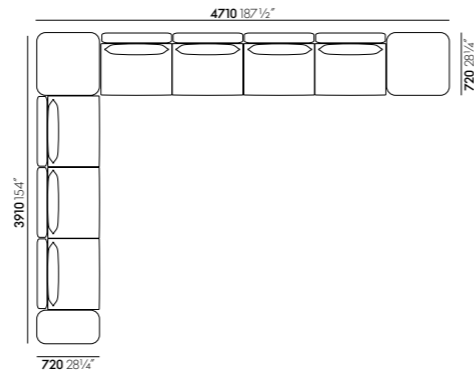

Soft Work corner sofa 7-seater, with corner table, table module and side table. Cover fabric: Cosy 2, 02 fossil.

Soft Work platform 8-seater double, 60° curve. Cover fabric: Cosy 2, 02 fossil.

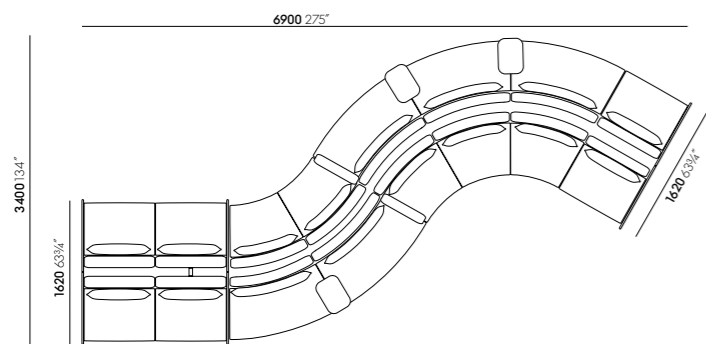

Soft Work sofa 8-seater double, highback with screens, 60°/90° S-curve. Cover fabric: Cosy 2, 03 nutmeg.

Configurations

vitra.

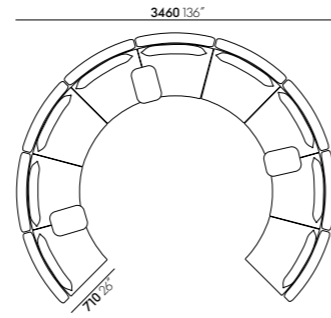

Soft Work sofa 9-seater, inner circle, 270° curve, with armrests and swivel tablets incl. flip-up socket.
Cover fabric: Laser, 23 yellow/pastel green.

vitra.

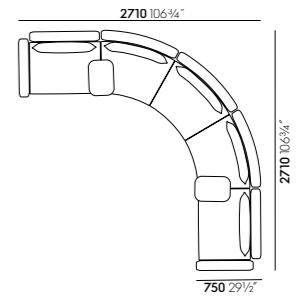

Soft Work sofa 5-seater, 90° curve, with side panels and swivel tablet incl. flip-up socket. Cover fabric: Cosy 2, 18 petrol.

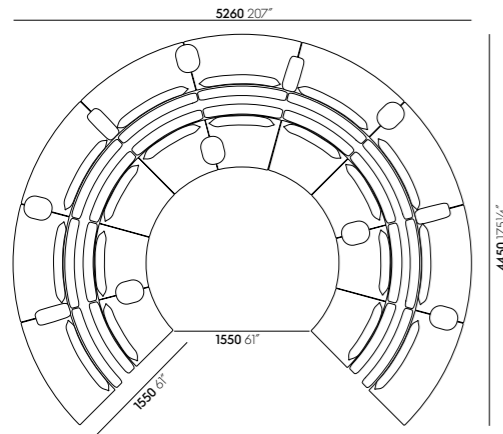

Soft Work sofa 9-seater double, inner/outer circle, 270° curve, with armrests and fixed trays incl. flip-up socket.
Cover fabric: Plano, 52 mint/forest.

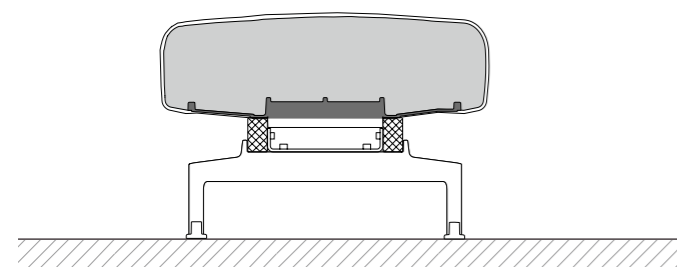

Soft Work platform
Platform module 80, 30° concave, 30° convex

Seat/back module: seat and back joined by two back brackets (CDP aluminium).
Platform module: seat only.

Seat modules: linear – support plate made of plastic (PA) in basic dark; curved – support plate made of MDF, powder-coated in black. Quick fastener (PA) for tool-free attachment to frame profiles integrated in support plate. Overlying moulded foam (PUR), not glued. Cover secured to support plate with Keder edging; removable.

Backrest: plastic core (PA) enveloped in foam (PUR). Removable cover.

Lumbar cushion: optional for seat/back modules. Chamber cushion, 50% foam lozenges, 50% feathers. Removable cover.

Frame: pair of profiles made of rectangular steel tubing (W 70 x D 40 mm), joined by spacer plates.

Leg base made of die-cast aluminium, with plastic glides for levelling adjustment (max. 20 mm) or with black castors Ø100 with lock.

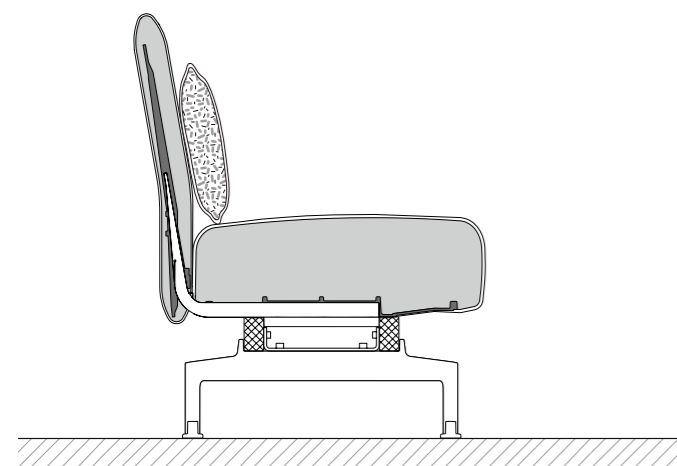

Soft Work
Seat/back module 80, 30° concave, 30° convex, lowback

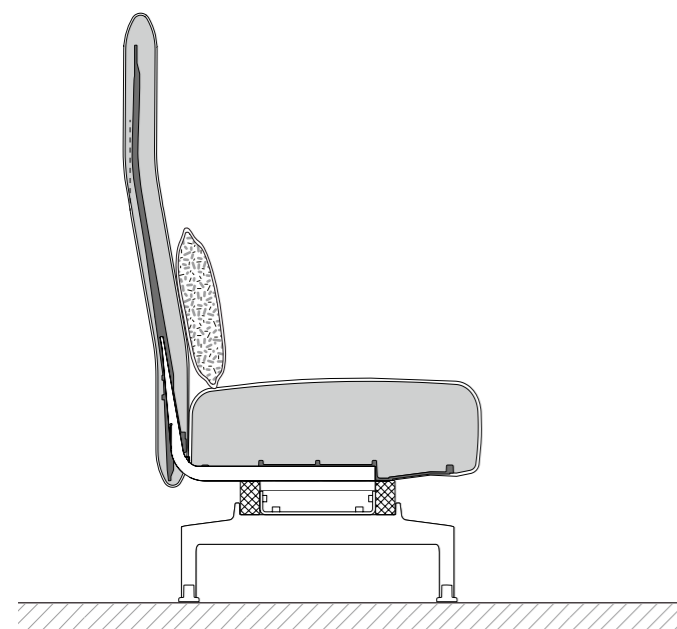

Soft Work High
Seat/back module 80 highback

Vitra has over fifty years of experience in the production of upholstered furniture. Premium materials, skilled craftsmanship and high quality standards at Vitra are a guarantee for long-lasting products. In Vitra's own test centre, our upholstered furnishings are regularly subjected to rigorous tests that far exceed common standards.

Care instructions:

Exposure to direct sunlight should be avoided, since ultraviolet rays can cause cover materials to fade.

To retain the original fullness and shape of your sofa, cushions should be regularly shaken and plumped.

Folds and creases from sitting can be prevented in all types of upholstery by smoothing the cover material after use.

Useful facts about cover materials

Cover fabrics have a decisive influence on the appearance and characteristics of upholstered furniture. Technical properties such as resistance to abrasion, fading or stains play an important role, along with the quality of fibres, weaving technique and aesthetic features of the textile.

Function and performance are primarily determined by the type of fabric used. In general, synthetic fibres are superior to natural fibres in terms of their technical characteristics. For this reason, blends of different materials are employed to combine the advantages of the individual fibres.

In the following, you will find some of the key features of the textiles used by Vitra in its upholstery covers:

Wool (WO)

Elastic natural fibre of animal origin, naturally self-cleaning – a brief airing disperses absorbed odours, leaving the wool smelling neutral and fresh again. Good resistance to light and abrasion, highly absorbent, minimal creasing, low flammability. Subject to pilling and matting.

Polyester (PE), Polyacrylic (PA), Viscose (VI)

Synthetic, highly uniform, lightfast fibres. The non-absorbent properties of synthetics can be mitigated with fibre blends and weaving techniques.

The overall look of a piece of furniture is influenced by the colour and type of cover fabric, its properties (elastic or non-stretch) as well as the upholstery technique (removable or attached covers). Consequently, a sofa can take on a different appearance depending on the cover material. Generally speaking, cover fabrics with some elasticity are less susceptible to creases and puckering, since they have an adaptable fit on three-dimensional forms. Heavier cover materials such as Over, Laser or Credo drape more smoothly, while thinner materials exhibit a finer rippling effect.

Care instructions:

All Soft Work covers are removable. Fabric covers can be professionally dry cleaned. Prior to treatment, please be sure to note the material composition of the cover fabric.

Should you ever need to replace individual parts or covers due to wear and tear, please contact your local Vitra retailer.

Colours and materials

Cosy 2 Home/Office, F80



Cosy 2 is a high-quality milled woollen cloth with a warm character. The lively melange yarn emphasises the fabric's natural colours – from delicate shades to vibrant hues – and gains added elegance with colour-coordinated stitching. The fabric offers thermal comfort and excellent durability, making it suited for upholstered furniture in office settings as well as residential applications.

Cosy 2 is available in 15 colours.

Material	20% polyamide, 80% new wool
Weight	590 g/m ² (17.4 oz/y ²)
Width	154 cm +/- 2 cm (60")
Abrasion resistance	50,000 Martindale
Fastness to light	Type 6
Pilling	Grade 4-5
Fastness to rubbing	Grade 4-5 dry and wet

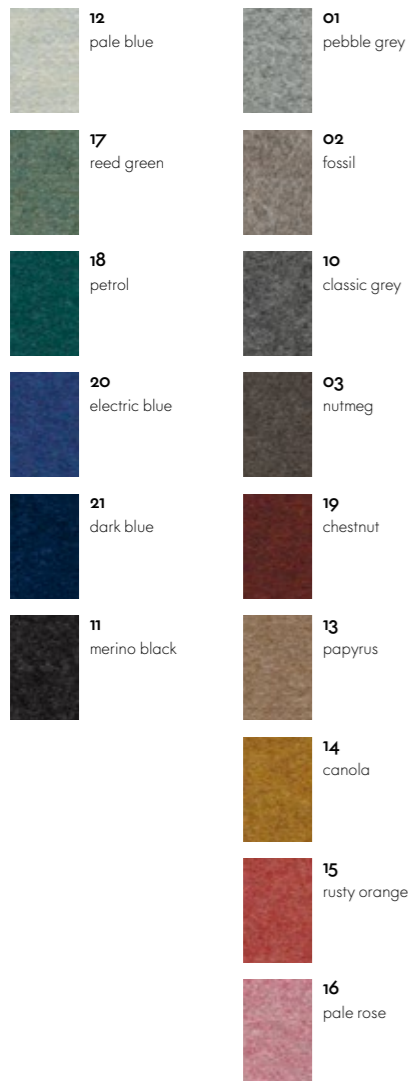

Credo Home/Office, F120

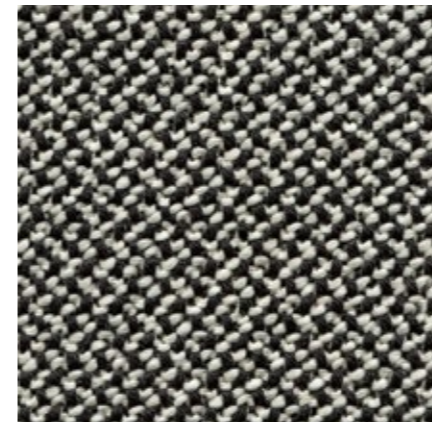

Credo is a durable woollen fabric made of premium worsted yarn with a pleasant feel. The two- and three-tone colours give this fabric a characteristic structure and vibrant appearance. Credo allows for an effective exchange of heat to ensure comfortable thermal conditions for the sitter. The fabric can also be used in office environments.

Credo is available in 22 colours.

Material	5% polyamide, 95% new wool
Weight	640 g/m ² (18.9 oz/y ²)
Width	145 cm +/- 2 cm (57")
Abrasion resistance	100,000 Martin- dale
Fastness to light	Type 6
Pilling	Grade 4-5
Fastness to rubbing	Grade 4-5 dry and wet



Laser RE Home/Office, F40

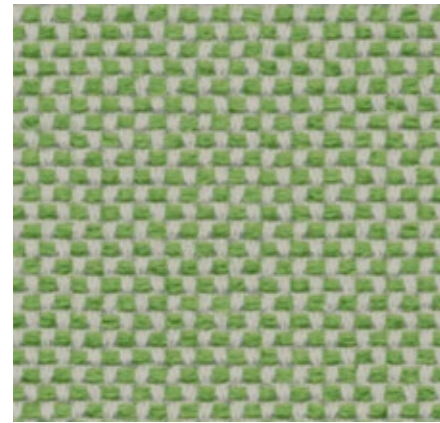

The environmentally friendly fabric Laser RE is made from recycled polyester. It has a distinctive woven appearance, which is particularly accentuated by contrasting duotones in a varied palette of 25 colours. Practical and easy to care for, as well as durable and highly abrasion-resistant, Laser RE is also well suited for office environments.

Laser RE is available in 25 colours.

vitra.

Material	100% recycled polyester
Weight	520 g/m ²
Width	144 cm +/- 2 cm
Abrasion resistance	100,000 Martindale
Fastness to light	Type 6
Pilling	Grade 4-5
Fastness to rubbing	Grade 4-5 dry and wet



Plano Home/Office, F30

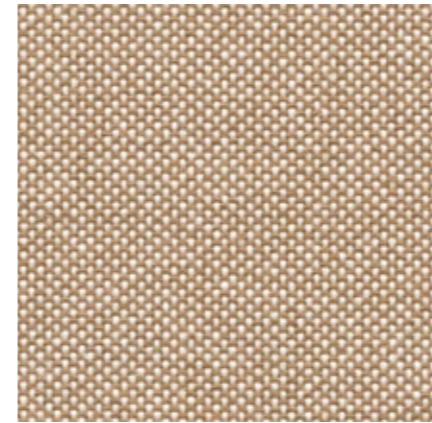

Plano is a robust plain weave with a flat, even texture. The wide palette of duotones with new, delicate washed-out shades includes many relatively neutral hues, a good number of which are coordinated with the Hopsak colour range. Thanks to its durability and longevity, Plano is also an ideal choice for office furnishings.

Plano is available in 39 colours.

vitra.

Material	100% polyester
Weight	265 g/m ² (7.8 oz/y ²)
Width	142 cm +/- 2 cm (56")
Abrasion resistance	80,000 Martindale
Fastness to light	Type 6
Pilling	Grade 4-5
Fastness to rubbing	Grade 4-5 dry and wet



Skai Pureto EN Home/Office, F60



Skai Pureto EN is a high-quality and durable PVC-free artificial leather. It mirrors the gentle texture of calfskin and has a similar feel to natural leather. Skai Pureto EN is a sustainable material, which is water-based as well as solvent-free. It is lightfast, robust and easy to clean, making it also suitable for areas of intensive use.

Skai Pureto EN is available in 7 colours.

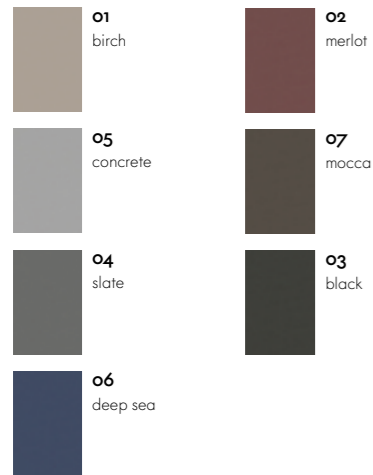

Material	21% cotton, 60% polyurethane, 19% polyester
Weight	640 g/m ²
Width	142 cm
Abrasion resistance	100,000 Martindale
Fastness to light	Type 6
Fastness to rubbing	Grade 4-5 dry and wet

vitra.

Volo Home/Office, F60

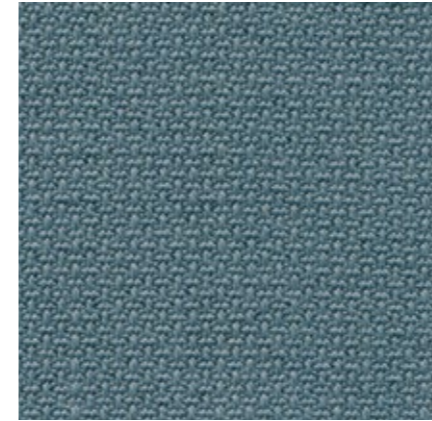

Volo is a finely structured wool blend with a refined weave that gives it an elegant appearance. This expressive textile shows strong solid colours to full advantage while simultaneously offering pleasant tactile qualities. With its soft look and appealing texture, Volo is a perfect fit for home interiors, but it is also well suited for use in the contract sector.

Volo is available in 17 colours.

Material	15% polyamide, 85% new wool
Weight	435 g/m ² (12.8 oz/y ²)
Width	145 cm +/- 3 cm (57")
Abrasion resistance	100,000 Martindale
Fastness to light	Type 6
Pilling	Grade 4-5
Fastness to rubbing	Grade 4-5 dry and wet

vitra.



Leather Home/Office, L20



The standard grade leather used by Vitra is a robust cowhide leather, dyed-through, pigmented and embossed with an even grain pattern. Since it is hard-wearing and easy to maintain, it can also be used in office environments.

Leather is available in 16 colours.



vitra.

Material	Robust cowhide with a distinctive, even grain
Fastness to light	Type 6
Thickness	1.1–1.3 mm
Fastness to rubbing	Grade 4 dry and wet

Leather Premium F Home/Office, L40



Leather Premium F is a relatively smooth cowhide leather with a flat grain and fine top sheen. It is dyed-through, lightly pigmented and processed with a tanning agent extracted from olive tree leaves (a waste product of the olive harvest).

Leather Premium F is available in 22 colours.

vitra.

Material	Semi-aniline nappa leather with a very soft and supple feel, vegetable tanned
Fastness to light	Type 5
Thickness	1.1–1.3 mm
Fastness to rubbing	Grade 4 dry and wet





52
soft light

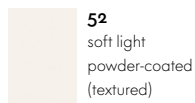

52
soft light
powder-coated
(textured)

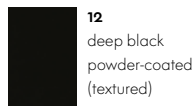

12
deep black
powder-coated
(textured)

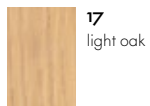

17
light oak

Table top



03
polished
aluminium

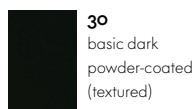

30
basic dark
powder-coated
(textured)

Base

