

# Joyn 2

Ronan & Erwan Bouroullec, 2023



**vitra.**

# Joyn 2

Ronan & Erwan Bouroullec, 2023



Inspired by the family table at the heart of their childhood home in Brittany, designers Ronan and Erwan Bouroullec developed the office table system Joyn together with Vitra in 2002: oversized shared tables serve as a platform for communication and teamwork. Joyn was the origin of a new office typology that promotes dynamic and spontaneous collaboration. Twenty years later, it still represents the norm in many companies. Joyn 2 enhances the iconic radicalism of the original design through the added dynamic functionality of a modern office table system geared to the

future, where employees share open workstations for collaborative tasks.

Joyn 2 is a simple, adaptable design made with durable materials to minimise the carbon footprint. The resulting system therefore features solid wood table tops, screens made of cork and desk pads using recycled leather remnants from Vitra's furniture production, as well as bases made of untreated aluminium – and those parts that are in plastic are manufactured largely from recycled sources. Designed in a colour scheme that matches this use of

sustainable materials, Joyn 2 has a fresh contemporary look and is suited as much for workshop-style offices as for elegant corporate environments.



## Ronan & Erwan Bouroullec

The brothers Ronan and Erwan Bouroullec live and work in Paris. Their oeuvre ranges from small everyday objects to architectural projects. They have worked with Vitra since 2000 and have contributed numerous designs to both the office and home collections.



## Solid wood

Joyn 2 elements made of this material: table tops

Wood is a natural material. Each piece therefore displays distinctive variations in grain, texture and colour, making each wooden furnishing an individual object. The surface is treated with oil to highlight and protect the natural characteristics of the wood. However, exposure to light will alter the colour of all wood types over time. Damage to the surface can be repaired on site.

The production of single-layer solid wood panels requires less energy and adhesive than those of other wood-based materials. The renewable raw material is a CO<sub>2</sub> reservoir. Wood expands and contracts differently depending on the room temperature and air humidity. In the case of multiple table tops, this can result in an offset (laterally and in height). In contrast to veneered tops, the wood pattern is not uniform when multiple solid wood table tops are combined. Vitra uses wood sourced in Europe.

## Untreated aluminium

Joyn 2 elements made of this material: legs

The surface of these aluminium parts is shot-blasted. Thanks to this treatment, no powder-coating is necessary. The result is a slightly textured, highly compacted surface. Free of any coating, it is more sensitive to finger marks. However, these can be removed with a cleaning agent and cloth. Untreated aluminium acquires a patina over time, with darker colouration and more of a matt finish. Whenever possible, Vitra uses aluminium consisting of 95% recycled material. Aluminium parts are extremely durable and can be re-injected into the aluminium recycling loop worldwide at the end of the product's lifespan.

## Cork

Joyn 2 elements made of this material: screens

Joyn 2 screens are made of untreated solid cork. To avoid the use of adhesives, Vitra uses solid material. Cork is a renewable raw material that is consistent with Vitra's commitment to sustainability. Each screen exhibits a different lively surface pattern marked by notches and colour variations.

## Reflect (fabric)

Joyn 2 elements made of this material: screens

Reflect is a sustainable fabric made of recycled polyester. Its twill weave offers a fine surface texture that is soft to the touch – exceptional for a textile manufactured from recycled fibres. As a highly robust material, Reflect meets the stringent requirements for use in public spaces. Designer Hella Jongerius developed nine colours for Reflect, which are harmoniously coordinated with the Vitra Colour & Material Library. The palette offered by Kvadrat – the manufacturer of the fabric – extends the selection by a further 35 hues. Slight variations in colour may occur.

## Bonded leather

Joyn 2 elements made of this material: Repad

The Repad desk pad is made of bonded leather. For this recycled material, remnants from Vitra's furniture production are shredded and enriched with vegetable tanning agents, natural rubber, fats and water and then dried. Repad has the pleasant feel of real leather and comes in five colours: a natural hue and four variants with a colour-coated finish. The palette is coordinated with the materials of the Joyn 2 office table system, but is also suited for use with any other table surface.

## Plastic RE

Joyn 2 elements made of this material: assorted small components

When developing Joyn 2, special attention was paid to using only as much plastic as necessary. For the five small plastic components that feature in Joyn 2, recycled material is utilised whenever technically feasible.



# Joyn 2 Platform

The Joyn 2 Platform serves as a basis for teamwork, and despite just four legs allows table lengths of up to 6.4 metres for 8 to 10 regular workspaces – with maximum legroom, easily accessible power and data options and diverse accessories for personalisation. The platforms emphasise the horizontal – only the accessories rise above the table surface.

Joyn 2 Platform is modular in design and easy to reconfigure in diverse formats. The table tops are available in three versions: as one-piece tops, as tops with a gap in the middle for easy access to power and data connections, and as a version with a technical rail – in the latter two versions, accessories can be fitted individually and repositioned as required. End table tops measuring 80 cm in depth add an additional fully-fledged workstation at either end of the table. Joyn 2 Platform can be adjusted from 74 to 82 cm in height.



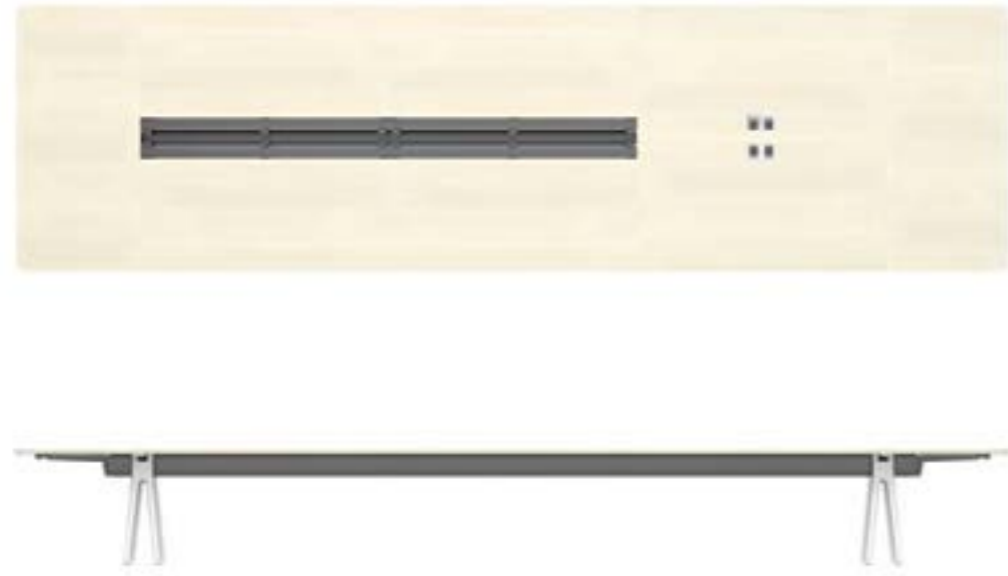

Joyn 2 can be designed with a clear span of up to 4.8 m between two pairs of legs. For longer configurations, an additional pair of legs is required in the centre.



Table tops are available in the lengths 120, 140, 160 and 240 cm.

The end tops exist in two sizes: 30 x 171 cm or 80 x 171 cm and have rounded ends.

Joyn 2 offers the choice of 3 types of table tops



**Continuous table tops**

for meeting zones. Diverse optional electrification features can be added.

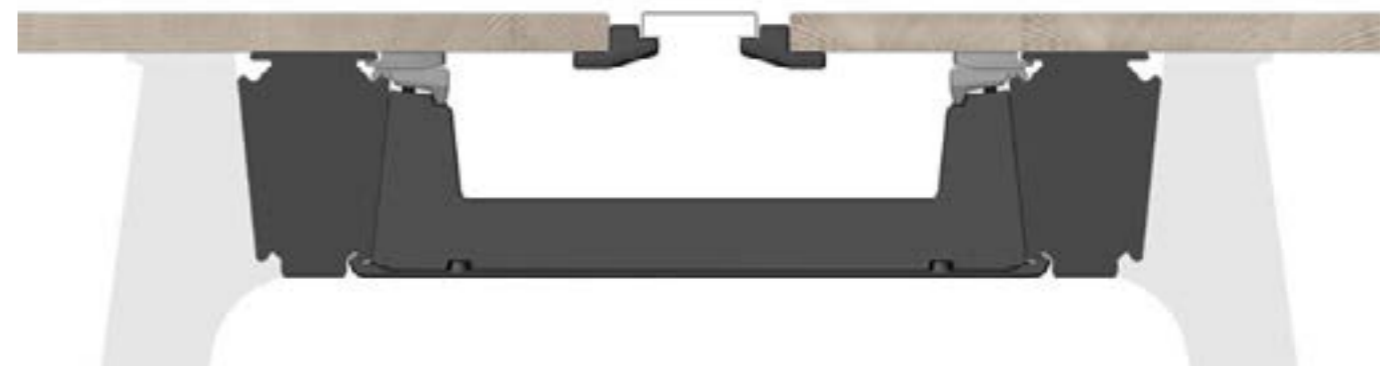

**Divided table tops with an 11-cm gap**

for work environments, with generous access to the cable channel. Accessories are mounted on the table top. Optional cable channel cover is available.

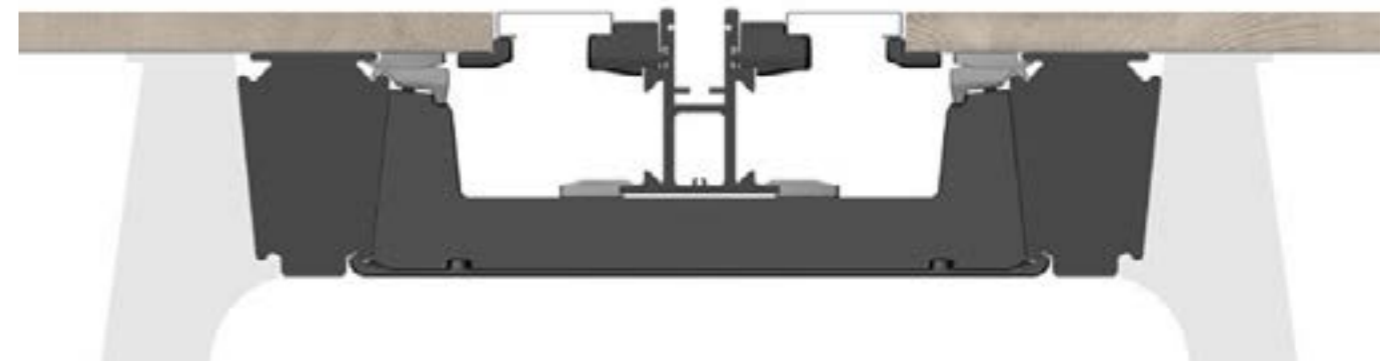

**Divided table tops with technical rail**

for work settings, with generous access to cable channel. The technical rail supports the accessories.

# Joyn 2 Platform with continuous table top



Continuous table tops (170 cm deep) can be equipped with the electrification options listed below.

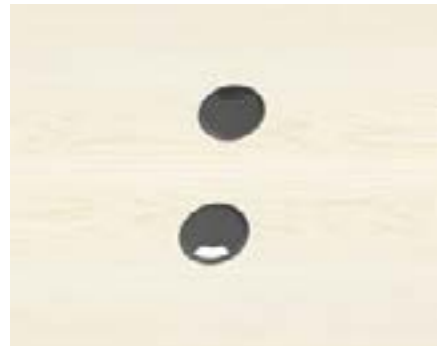

Cable outlet 80

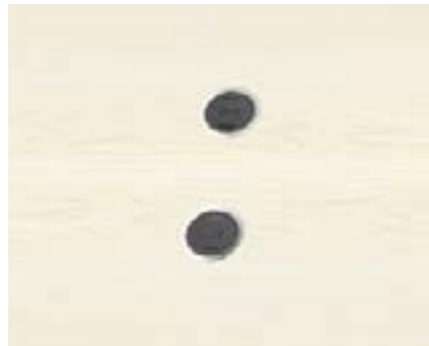

Punto Wireless Charger 80



Port 180  
(power/USB/cable outlet)



Evoline Circle 80  
(power/USB/cable outlet)



Punto high 80 (power/USB)

# Joyn 2 Platform with divided table top



For the divided table top with an 11-cm gap, accessories include central screens, insertable screens, desktop socket strips and mounting brackets for table lamps and monitors. All elements are attached to the table top.

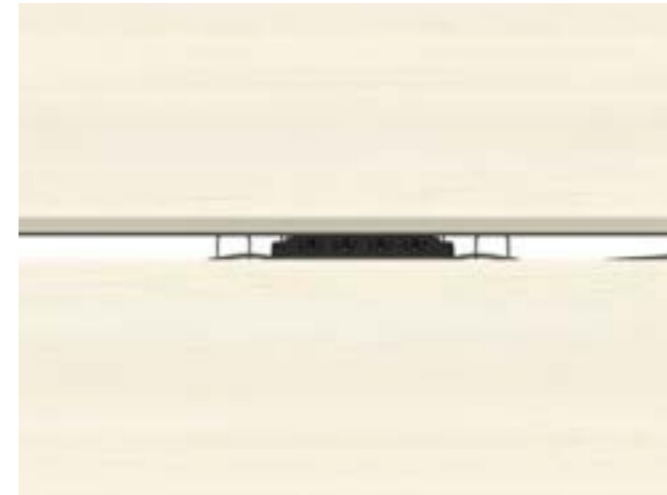

Open channel for free access to undertable electrification.



Cable channel with cover: two 2-cm wide slits remain for cable routing and the connection of accessories. The covers can be simply lifted up and removed at any time.

## Joyn 2 Platform with divided table top and technical rail

vitra.



For the divided table top with a technical rail, accessories include central screens, insertable screens, desktop socket strips, mounting brackets for table lamps and monitors, as well as central shelves. All elements are supported by the technical rail, freeing up more space on the table top.



The addition of removable covers creates a flat continuous table surface. Two 3-cm wide slits remain for cable routing and the connection of accessories. The covers can be simply lifted up and removed at any time.

## Joyn 2 Platform Electrification options and height adjustment

vitra.



The wide cable channel can be fitted with cable baskets for the purpose of holding electrification equipment. The cable baskets are hooked into place from below without tools, and can be removed as and when needed. They allow subsequent access to electrical installation through the open base. Undertable socket strips or power distributors can be installed in the cable baskets along with excess cable length. The feed cable is routed directly into one of the cable baskets.



The table height can be adjusted from 74 - 82 cm.



The Joyn 2 base is available in soft light or black.



















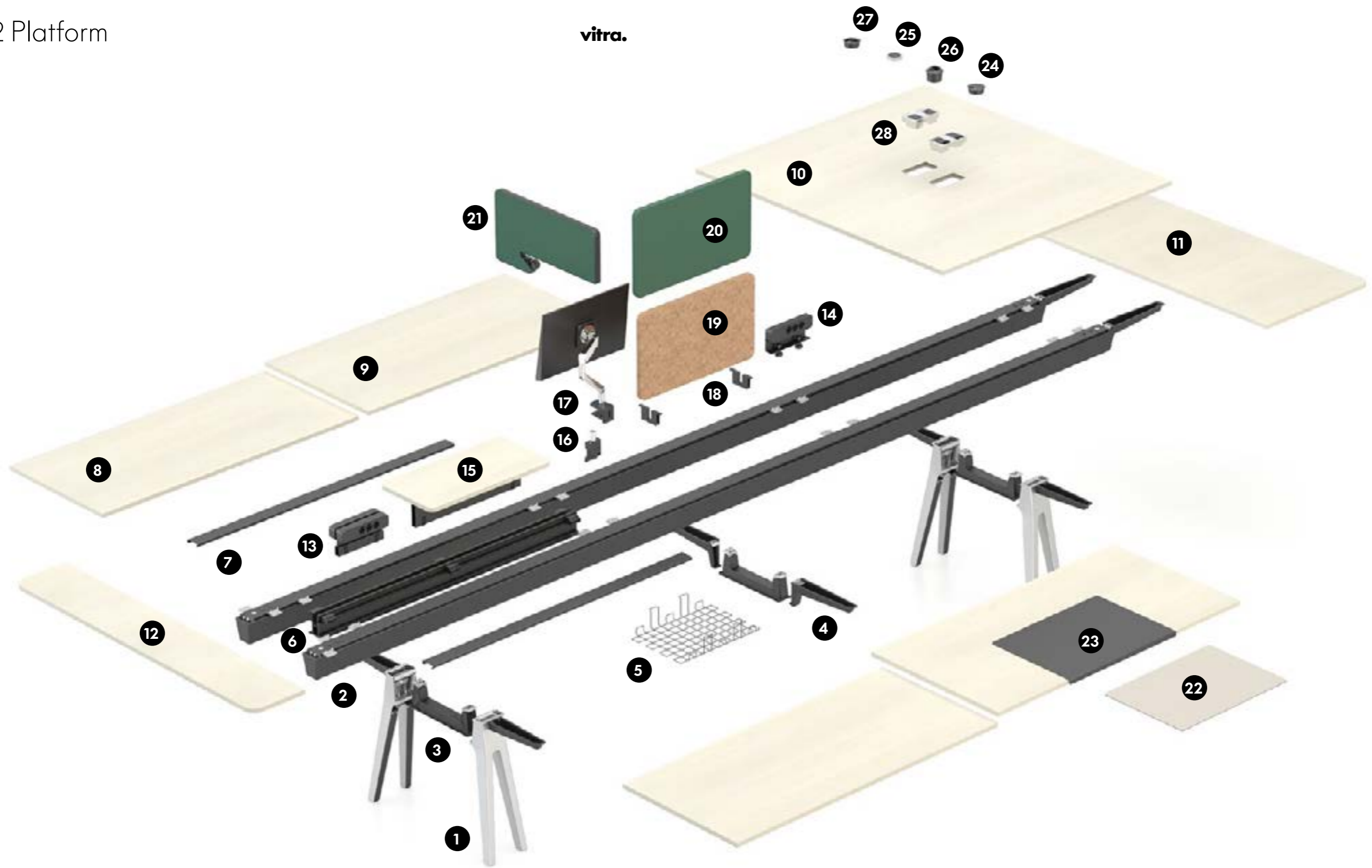

- |                      |                                 |  |   |                              |                      |
|----------------------|---------------------------------|--|---|------------------------------|----------------------|
| 1 Trestle            | 6 Technical rail                | 11 End top 80 cm                                 | 16 Monitor and lamp adapter for use on technical rail | 21 Insertable side screen    | 26 Punto high 80     |
| 2 Profile            | 7 Cable channel cover           | 12 End top 30 cm                                 | 17 Mounting bracket for lamp or monitor               | 22 Repad (desk pad)          | 27 Evoline Circle 80 |
| 3 Cross-connector    | 8 Table top for technical rail  | 13 Double socket strip for use on technical rail | 18 Screen holder                                      | 23 Desk pad                  | 28 Port 180          |
| 4 Table top supports | 9 Divided table top, 80-cm deep | 14 Desktop socket strip                          | 19 Central cork screen                                | 24 Cable outlet 80           |                      |
| 5 Cable basket       | 10 Continuous table top         | 15 Central shelf, optional with socket           | 20 Central fabric screen                              | 25 Punto Wireless Charger 80 |                      |



## Joyn 2 Touchdown

Joyn 2 Touchdown tables are designed for temporary use: the user has quick and easy access to power and data options, while screens provide acoustic and visual privacy for focused tasks. Joyn 2 Touchdown can be configured with table top lengths from 200 to 900 cm (in one-metre increments), in sitting or standing-height variants, on glides or on castors. Furniture with castors promotes dynamic work methods in the office, while variants with glides ensure that electrification cables can be concealed in the table legs.



## Joyn 2 Touchdown

vitra.



For divided table tops with an 11-cm gap, accessories include central screens, insertable screens, desktop socket strips and mounting brackets for table lamps and monitors. All elements are attached to the table top.



The cable channel can be optionally closed by the use of covers flush with the table top, thus creating a flat continuous surface. Two 2-cm wide slits remain for cable routing and the connection of accessories. The covers can be simply lifted up and removed at any time.

## Joyn 2 Touchdown

vitra.



Touchdown tables exist in sitting-height (74 cm) and standing-height (110 cm) versions and are narrower in depth (140 cm) than the Joyn 2 Platform. The base consists of a frame construction with individual legs and the tables are available in lengths of 2 m, 3 m, 4 m, 5 m and 6 m. For lengths exceeding 3 m, two additional legs are added in the centre. Other sizes can be configured and ordered using the pCon Planner.



Cable baskets beneath the table top can be equipped with electrical sockets and used to store excess cable length.



With versions standing on glides, cables can be routed through the legs.

Touchdown tables are also available with castors.





















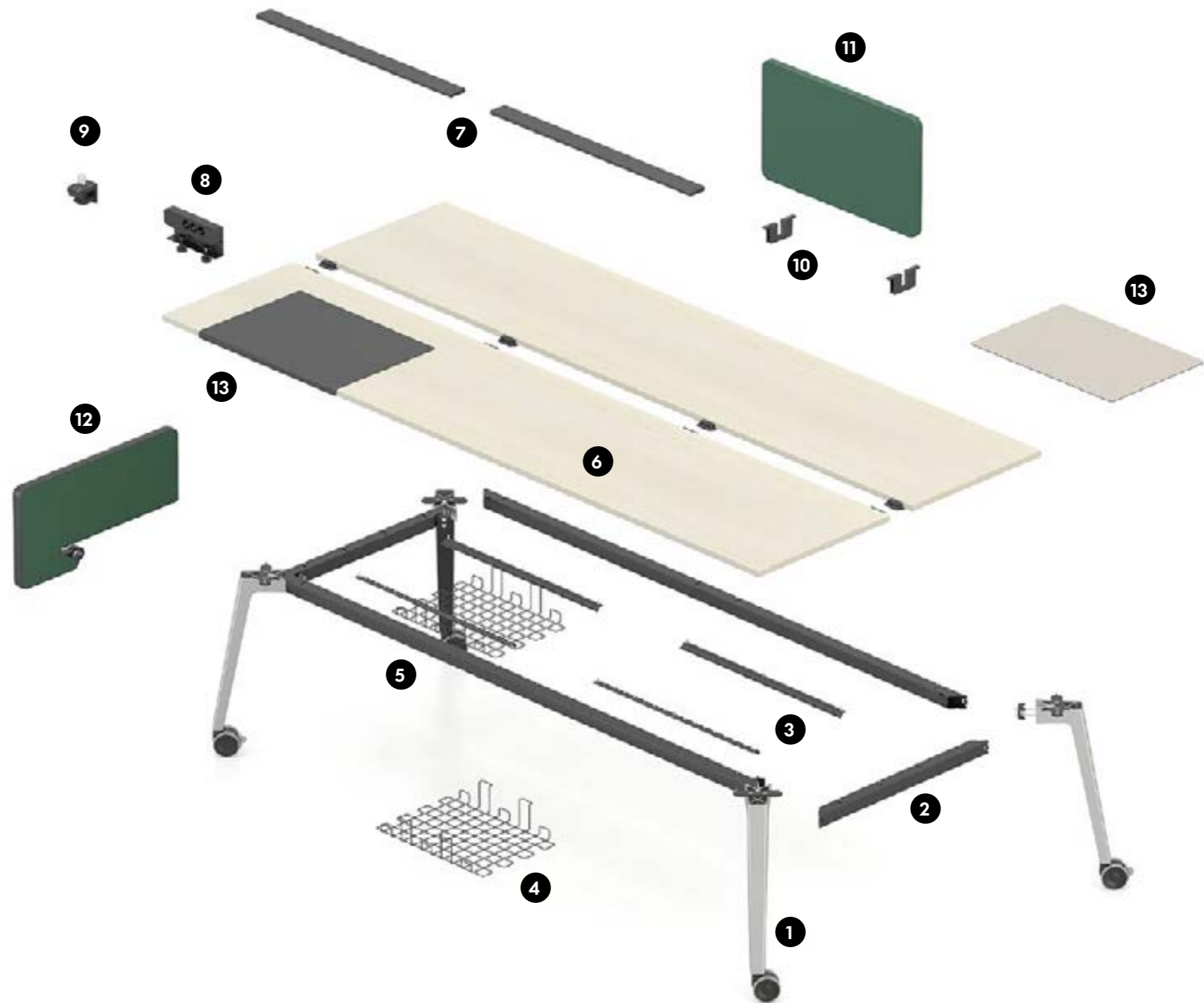

- 1 Single leg
- 2 Frame tube
- 3 Cable basket holders
- 4 Cable basket
- 5 Undertable socket strip
- 6 Table top
- 7 Cable channel cover
- 8 Desktop socket strip
- 9 Mounting bracket for lamp or monitor
- 10 Screen holder
- 11 Central screen (fabric or cork)
- 12 Insertable screen
- 13 Repad (desk pad)



## Joyn 2 Meet

Joyn 2 Meet offers meeting tables ranging from 120 x 80 cm to 900 x 180 cm. The base can be configured in diverse shapes and sizes for sitting or standing-height tables – on either glides or castors. Furniture on castors promotes dynamic work methods in the office, while variants with glides enable electrification cables to be concealed in the table legs.



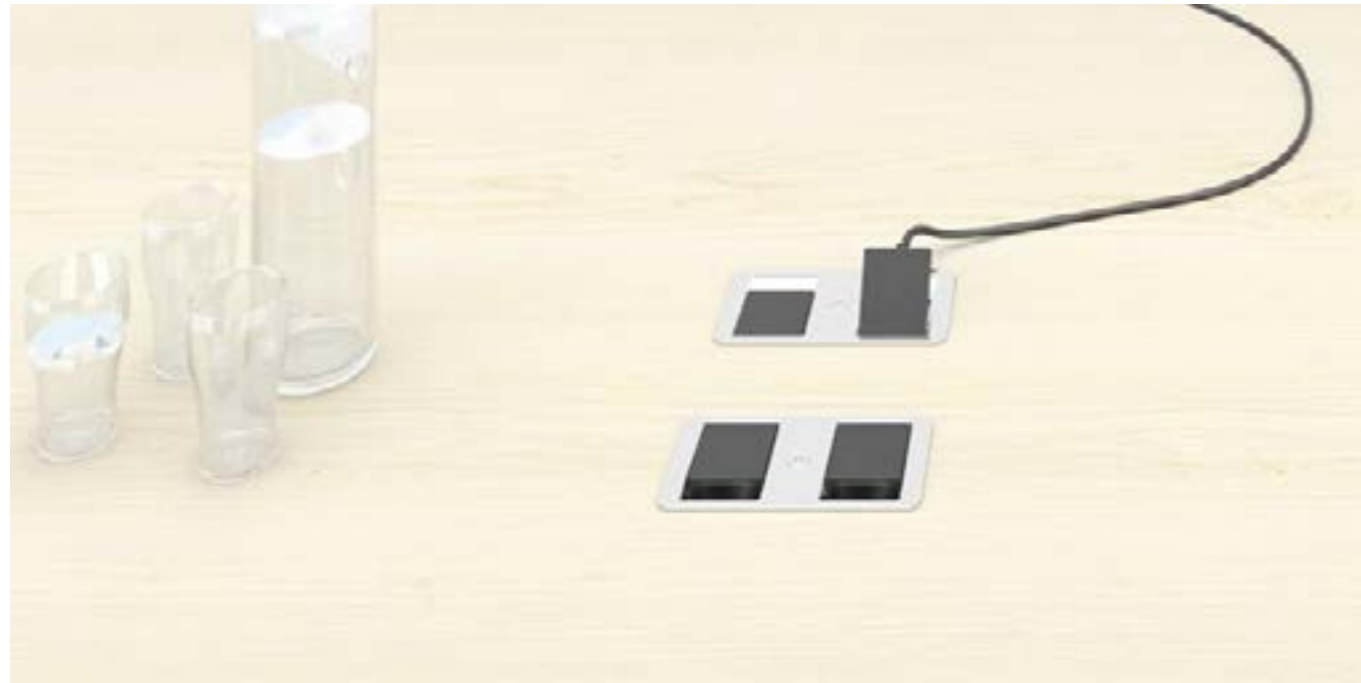

Joyn 2 Meet exists in sitting-height (74 cm) and standing-height (110 cm) versions and comes with a choice of electrification options.

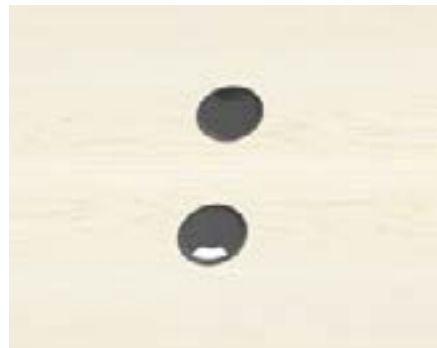

Cable outlet 8o

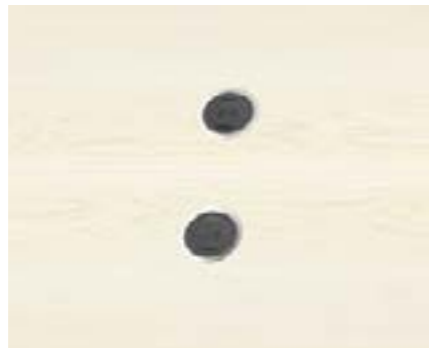

Punto Wireless Charger 8o



Port 18o  
(power/USB/cable outlet)



Evoline Circle 8o  
(power/USB/cable outlet)



Punto high 8o (power/USB)



Aletta



Joyn 2 Meet is available in 5 sizes for sitting-height and standing-height models: Ø 120 cm, 120 x 120 cm, 240 x 100 cm, 320 x 100 cm and 400 x 140 cm. Other sizes can be configured and ordered using the pCon Planner.



With versions standing on glides, cables can be routed through the legs.



The tables are also available with castors.













- 1 Single leg
- 2 Frame tube
- 3 Cable basket holders
- 4 Cable basket
- 5 Undertable socket strip
- 6 Table top
- 7 Cable outlet 8o
- 8 Punto Wireless Charger 8o
- 9 Evoline Circle 8o
- 10 Port i8o
- 11 Aletta





Joyn 2  
in HPL basic dark, anti-fingerprint coating



Joyn 2  
in light oak veneer





Joyn 2  
in melamine soft light





## Environmental Product Passport

The Environmental Product Passport contains information about the product carbon footprint, recycling, material composition, packaging & logistics, the supply chain and available product certificates. If you have any questions about the Environmental Product Passport or other queries about sustainability, please feel free to contact us at [sustainability@vitra.com](mailto:sustainability@vitra.com)

To offer transparency with regard to a product's most important environmental factors, Vitra provides certificates from external testing institutes. For this purpose, Vitra focuses on a selection of certificates that explicitly cover key elements of the respective product.

## Greenguard

The GREENGUARD label for indoor air quality recognises products that contribute to the creation of healthier indoor environments.



## GS

With the GS seal for tested safety, a state-authorized inspection institute certifies the suitability and safety of the construction and monitors production at regular intervals.



## Ergonomics Approved

The 'Ergonomics Approved' certificate confirms the fulfilment of ergonomic requirements and testing criteria that exceed the minimum legal regulations for office swivel chairs.



## BIFMA

Tyde 2 fulfils the ANSI/BIFMA standard X5.1-2011, thus meeting the stringent safety requirements for the US market.



## EPD

An EPD - environmental product declaration - provides transparency about the environmental impacts of a product throughout its life cycle, often referred to as life cycle assessment (LCA).





## Spare parts

Castors and glides can be ordered directly from the [vitra.com](https://www.vitra.com) website.  
[Link to online shop](#)  
For other spare parts, please contact Vitra or your local Vitra partner.  
[Link to service contact form](#)



## Care instructions

Here you will find care instructions for cover fabrics, leather, plastics and metals.  
[Link to website](#)



## Warranty & maintenance

General two-year warranty on Joyn 2.  
For matters relating to maintenance and repair or general enquiries, contact our Service Team using the following form.  
[Link to Service Team contact form](#)



## Find Vitra

Here you can find the nearest Vitra location or a Vitra partner for local assistance.  
[Find Vitra](#)



# Dimensions

(in accordance with EN 1335-1:2000)

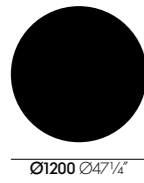

Joyn 2 Meet table  $\varnothing$  120 cm, table height 74/110 cm

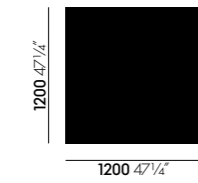
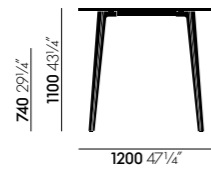

Joyn 2 Meet table 120 x 120 cm, table height 74/110 cm

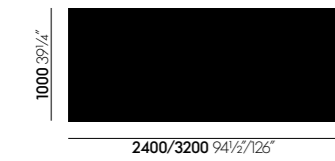
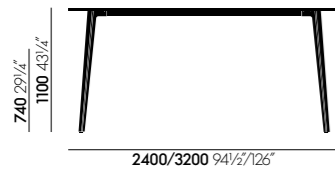

Joyn 2 Meet table 240/320 x 100 cm, table height 74/110 cm

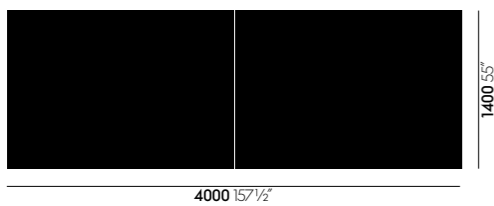
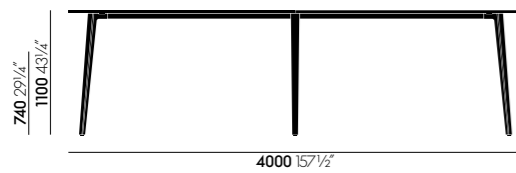

Joyn 2 Meet table 400 x 140 cm, table height 74/110 cm

vitra.

vitra.

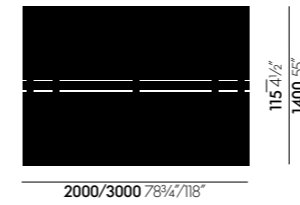
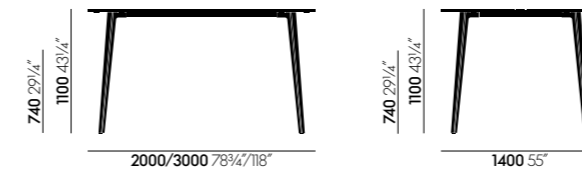

Joyn 2 Touchdown table 200/300 x 140 cm, table height 74/110 cm

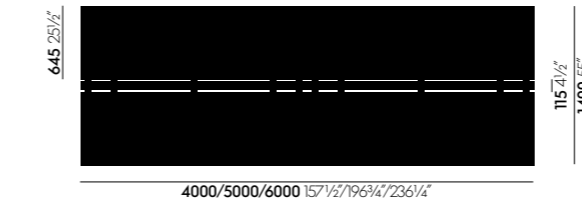
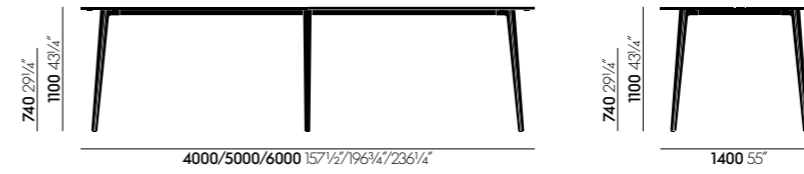

Joyn 2 Touchdown table 400/500/600 x 140 cm, table height 74/110 cm



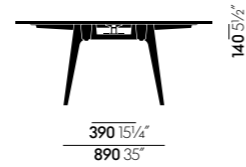
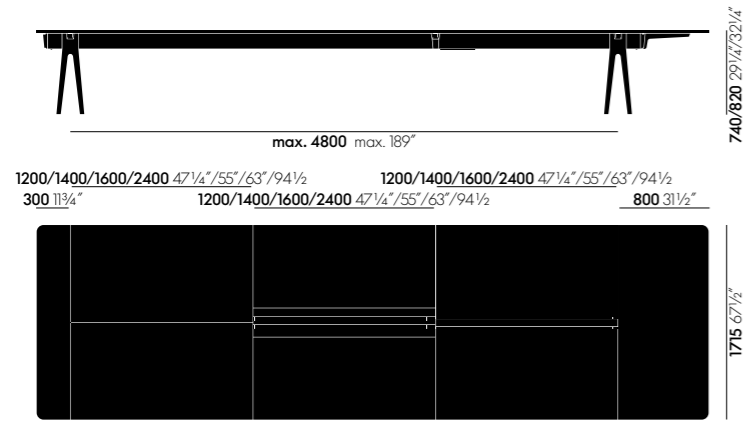

Joyn 2 Platform

	52 soft light powder-coated (textured)	17 light oak	03 clay
96 blasted alu- minium	77 cotton white ash, oiled	47 mauve grey	04 light sage
12 deep black powder-coated (textured)	30 basic dark anti-fingerprint (smooth)	30 basic dark	05 dark red
<b>Legs</b>	<b>Table top</b>	<b>Blotter</b>	<b>Bonded leather</b>
			06 jade
			02 natural black

Additional elements



Central cork / fabric screen



Central shelf



Side screen

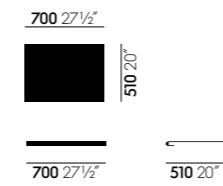

Desk blotter



Repad

# Plano Heavy use, F30



Plano is a robust plain weave with a flat, even texture. The wide palette of duotones with new, delicate washed-out shades includes many relatively neutral hues, a good number of which are coordinated with the Hopsak colour range. Thanks to its durability and longevity, Plano is also an ideal choice for office furnishings.

Plano is available in 39 colours.

Material	100% polyester
Weight	265 g/m <sup>2</sup> (7.8 oz/y <sup>2</sup> )
Width	142 cm +/- 2 cm (56")
Abrasion resistance	80,000 Martindale
Fastness to light	Type 6
Pilling	Grade 4-5
Fastness to rubbing	Grade 4-5 dry and wet

## Plano (central screens and insertable side screens)



# Reflect Heavy use, F40



Reflect is a sustainable fabric made of recycled polyester. Its twill weave offers a fine surface texture that is soft to the touch. As a highly robust material, Reflect meets the stringent requirements for use in public spaces.

Hella Jongerius has designed nine colours, which are harmoniously coordinated with the Vitra Colour & Material Library. The Kvadrat palette extends the selection by a further 35 hues. Slight variations in colour may occur.

Material	100% recycled polyester
Weight	310 g/m <sup>2</sup> (9.1 oz/y <sup>2</sup> )
Width	142 cm +/- 2 cm (56")
Abrasion resistance	100,000 Martindale
Fastness to light	Type 6
Pilling	Grade 4-5
Fastness to rubbing	Grade 4-5 dry and wet

## Reflect (central screens and insertable side screens)

