



## WEDGE | INDOOR - OUTDOOR

design Arik Levy

Rectangular table, available for indoor and outdoor use.

**Indoor version:** wooden table with 40 mm thick honeycomb top in balanced fir wood, reinforced with 25x15 mm steel tubes, and legs in birch plywood. Veneered top with slabs and top edging in 4 mm solid natural chestnut, charcoal-dyed chestnut and Stone Oak® with water-based acrylic finish, or in multilayer wood veneer Striped Grey with acrylic painting. The legs are screwed to the top using steel plates with polyurethane paint finish.

**Indoor/outdoor version:** aluminum table with 28 mm thick aluminum honeycomb top with a folding technique and 1 mm aluminum sheet; legs made of 5 mm folding-shaped aluminum honeycomb panels. Finish with aluminum primer and finished with scratch-resistant matt paint in black, RAL 9001 White Cream or NCS S 6000-N grey color, or Cement Effect finish in col. Chiaro and col. Scuro. The legs are screwed to the top with steel plates, with outdoor polyurethane finish.

### Top and Legs

	Natural Chestnut (Indoor)		Charcoal-dyed Chestnut (Indoor)		Stone Oak® (Indoor)		Striped Grey (Indoor)
	Cement Effect Finish col. Scuro (In-Outdoor)		Cement Effect Finish col. Chiaro (In-Outdoor)		Scratch-resistant Lacquered col. Matt Black (In-Outdoor)		Scratch-resistant Lacquered Matt RAL 9001 White Cream (In-Outdoor)
	Scratch-resistant Lacquered Matt NCS S 6000-N Grey (In-Outdoor)						

## Technical Drawings

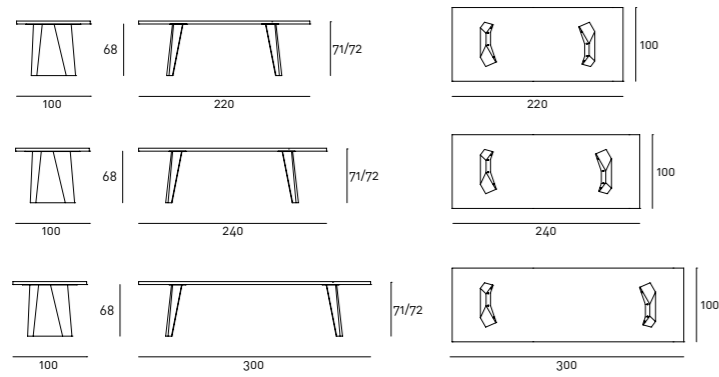

## Notes

Wood is a living material; therefore, it can have slight color and dimension changes. The presence of any non-homogeneous color shades is not to be considered a defect but a quality. Please note that the direct sunlight exposure may alter the wood color; therefore, we recommend the periodic position shift of the objects placed on the furniture for the first months to avoid differences in shades between exposed and covered portions.

**STRIPED GREY:** it is a decorative multilaminar wood veneer, always finished with a transparent acrylic painting, which features exclusive patterns reproducing the natural characteristics of wood. We would like to remind you that, being a natural and living wooden material, it may present non-homogeneous colour shades, which are peculiarities of the material itself.

**STONE OAK®:** this wood owes its particular coloring to an entirely natural process. Because of this, some slabs may look more brown than others. Our commitment is to provide you a high-quality product; any differences in color should not be considered as defects.

On request, an additional protective (acrylic solvent) painting is available for the Stone Oak® finishing only. It should be noted that this additional coating slightly changes the natural color and texture of the surface. Although this supplementary painting increases the surface resistance, it is still a natural material; therefore, small superficial stains, due to oil or other substances, must be promptly removed, before being absorbed in depth by the wood. Thus, we recommend regular care and maintenance.

On request, for wooden version only, table with dimension 340x100x73 cm in the finishing available in the collection.

**"CEMENT EFFECT" FINISH:** finish obtained by cement-based materials applied manually, after sanding the surface, through different phases: 2 layers of primer coating applied with a brush and roller; 2 layers of the cement applied with a specific spatula – each stage is spaced by a 24h drying cycle, and further sanding before proceeding to the next phase – and final phase of 2 protective finishes, applied with a brush, as stain-resistant treatment, which prevents the immediate absorption of stains. The cement finish is furthermore protected with an acrylic paint finish, which provides the surface a good scratch resistance. A subsequent application of nano-molecular varnish, protects the finish from chemical agents, especially of food nature. The handcraft and preciousness of this application, creates finishes and surfaces which may differ from each other for finishing and shades of colours. This feature shows the exclusivity and craftsmanship of each creation.

For the **OUTDOOR** version, we recommend placing the product on terraces or verandas to guarantee its durability over the years. It is recommended to use a "Protective Cover" to improve the longevity of the product. For further information about the dedicated maintenance, please refer to the technical sheet available in the "Materials" section on our website.

The scratch-resistant coating increases scratch resistance compared to standard coatings, but doesn't completely eliminate the possibility of scratches on the surface.



