

101

C O P E N H A G E N



BIG FOOT TABLE TALL

At first glance the Big Foots collection looks heavy and dense, yet on further inspection, the fiber concrete bench, side tables and coffee table are lightweight and mobile.

With nods to brutalist architecture and the world of contemporary sculpture, the cylinder-shaped legs and textured, painted surfaces makes the collection stand out in the crowd.

All products are cast in lightweight fiber concrete to create a unique textured surface and increase mobility. Each piece is hand painted with multiple layers of paint, creating a strong and resistant surface

Designed by Kristian Sofus Hansen & Tommy Hyldahl.

Product no: 233005

Type: Table

Designer / Year of design:
Kristian Sofus Hansen & Tommy Hyldahl, 2022

Colour: Bone White

Material: Fiber Concrete

Care instructions:
Use a soft dry cloth to clean the product.
Do not use household cleaners.
Not frost-proof

Dimensions: L45 / W45 / H51 CM

Country of origin: CN

Product weight: 12,8 Kgs

Packaging:
Dimensions: L54 / W53 / 62 CM
Total weight incl. product: 14 Kgs
Number of parcels: 1
Material: Brown cardboard

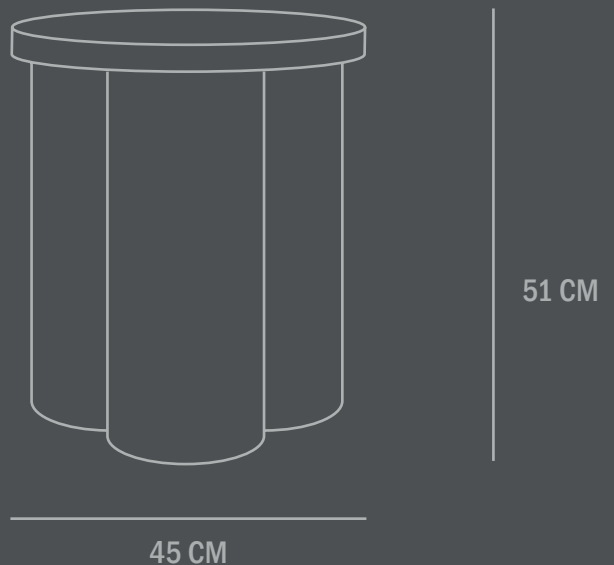

101

C O P E N H A G E N



BIG FOOT TABLE TALL

At first glance the Big Foots collection looks heavy and dense, yet on further inspection, the fiber concrete bench, side tables and coffee table are lightweight and mobile.

With nods to brutalist architecture and the world of contemporary sculpture, the cylinder-shaped legs and textured, painted surfaces makes the collection stand out in the crowd.

All products are cast in lightweight fiber concrete to create a unique textured surface and increase mobility. Each piece is hand painted with multiple layers of paint, creating a strong and resistant surface

Designed by Kristian Sofus Hansen & Tommy Hyldahl.

Product no: 211003

Type: Table

Designer / Year of design:
Kristian Sofus Hansen & Tommy Hyldahl, 2019

Colour: Coffee

Material: Fiber Concrete

Care instructions:
Use a soft dry cloth to clean the product.
Do not use household cleaners.
Not frost-proof

Dimensions: L45 / W45 / H51 CM

Country of origin: CN

Product weight: 12,8 Kgs

Packaging:
Dimensions: L54 / W53 / 62 CM
Total weight incl. product: 14 Kgs
Number of parcels: 1
Material: Brown cardboard

